

**User's Manual**

P/N 063015-003

# 3240 Bar Code Label Printer

 **ntermec**

A **UNOVA** Company

Intermec Corporation  
6001 36th Avenue West  
P.O. Box 4280  
Everett, WA 98203-9280

U.S. technical and service support: 1-800-755-5505  
U.S. media supplies ordering information: 1-800-227-9947

Canadian technical and service support: 1-800-688-7043  
Canadian media supplies ordering information: 1-800-268-6936

Outside U.S. and Canada: Contact your local Intermec service supplier.

The information contained herein is proprietary and is provided solely for the purpose of allowing customers to operate and/or service Intermec manufactured equipment and is not to be released, reproduced, or used for any other purpose without written permission of Intermec.

Information and specifications in this manual are subject to change without notice.

© 1997 by Intermec Corporation  
All Rights Reserved

The word Intermec, the Intermec logo, JANUS, IRL, TRAKKER, Antares, Duratherm, Precision Print, PrintSet, Virtual Wedge, and CrossBar are either trademarks or registered trademarks of Intermec Corporation.

Novell is a registered trademark of Novell, Inc.

Kimdura is a registered trademark of Kimberly Clark.

Kapton is a registered trademark of Dupont.

Speedo, Dutch, and Swiss are registered trademarks of Bitstream Inc.

The name Centronics is wholly owned by GENICOM Corporation.

IBM is a registered trademark of International Business Machines Corporation.

Throughout this manual, trademarked names may be used. Rather than put a trademark (™ or ®) symbol in every occurrence of a trademarked name, we state that we are using the names only in an editorial fashion, and to the benefit of the trademark owner, with no intention of infringement.

## ***Manual Change Record***

This page records the changes to this manual, which was originally released as version 001.

<b>Version</b>	<b>Date</b>	<b>Description of Change</b>
002	10/96	These two addenda were added: <ul style="list-style-type: none"><li>• Self-strip addendum Part No. 064196-001</li><li>• Top of form addendum Part No. 064522-001</li></ul> Other minor corrections and changes were made throughout the manual.
003	11/97	Removed Chapters 5 and 6, which pertained to IPL commands. This information is now contained in the <i>IPL Programming Reference Manual</i> .



# Contents

<b>Before You Begin</b>	<b>xi</b>
Warranty Information	xi
Safety Summary	xi
Warnings and Cautions	xii
About This Manual	xiii

## 1

---

### **Getting Started**

#### **Unpacking the 3240 Printer 1-3**

Checking the Order for Completeness	1-4
Reporting Damage or Defects	1-4

#### **Getting to Know Your 3240 Printer 1-5**

#### **Preparing the Printer for Installation 1-7**

Plugging In the Printer	1-7
Opening the Printer	1-8
Loading a Roll of Media	1-9
Printing the Hardware Configuration Test Label	1-12
What the Hardware Configuration Test Label Tells You	1-13
If the Hardware Configuration Test Label Does Not Print	1-13

#### **Connecting the Printer to Your System 1-13**

Connecting the 3240 to a PC	1-14
Connecting the Printer to a PC Serial Port	1-14
Connecting the Printer to a PC Parallel Port	1-15
Connecting the 3240 to a Network	1-15
Connecting the 3240 to an AS/400	1-16
Connecting the 3240 to a Mainframe	1-16

#### **Configuring the Serial Port 1-17**

#### **Verifying Printer Communications With Your System 1-19**

## 2

---

### **Operating the Printer**

#### **Learning How to Operate the Printer 2-3**

#### **Understanding the Front Panel 2-3**

Using the Front Panel LEDs	2-4
Using the Front Panel LEDs for Troubleshooting	2-4

*Using the Feed/Pause Button 2-5*

**Loading Media Into the Printer 2-6**

*Loading Media for Fanfold Printing 2-6*

*Loading Media for Self-Strip Printing 2-8*

**Loading Thermal Transfer Ribbon 2-11**

**Setting the Media Sensitivity Number 2-13**

*Setting the Media Sensitivity Number for Intermec Media and Ribbon 2-14*

*Setting the Media Sensitivity Number for Other Media and Ribbon 2-15*

**Communicating With the Printer 2-17**

*Using the PrintSet Software 2-17*

*Using Third-Party Software 2-17*

*Using the Intermec Printer Language (IPL) Commands 2-17*

*Printing a Test Label 2-18*

*Using a Different Platform Than a PC 2-19*

---

**3**

**Maintaining the Printer**

**Inspecting the Printer 3-3**

**Cleaning the Printer 3-3**

**Maintenance Schedule 3-4**

*Cleaning the Printhead 3-6*

*Cleaning the Printer Covers 3-7*

*Cleaning the Rollers and the Tear Bar 3-8*

*Cleaning the Media Guides and Media Path 3-10*

*Cleaning the Label Sensors 3-12*

---

**4**

**Troubleshooting**

**Troubleshooting Checklist 4-3**

**Printer Operation Problems 4-3**

**Print Quality Problems 4-5**

**Communications Problems 4-7**

**Preventing Data Loss 4-8**

**Optimizing and Maintaining Print Quality 4-9**

- Selecting the Correct Media* 4-9
- Setting the Print Speed* 4-10
- Selecting the Correct Media Sensitivity Number* 4-10
- Selecting the Correct Bar Code Orientation* 4-10
- Adjusting the Print Darkness* 4-11
- Adjusting the Printer for Self-Strip Printing* 4-12
- Using Precision Print Technology to Print High Registration Labels* 4-13
  - Correcting the Lateral Position of the Label Image* 4-13
  - Accurately Detecting the Start of a Label* 4-15
  - Correcting Uneven Print Quality* 4-17
  - Fine-Tuning the Top of Form Position* 4-19

## 5

### **Performing Advanced Procedures**

#### **Using the Printer Memory Efficiently 5-3**

- How Is the 3240 RAM Used?* 5-3
- Making the Most of Your RAM* 5-4

#### **Maximizing Throughput 5-5**

- What Is an Image Band?* 5-5
- How the Image Bands Command Works* 5-6
- Optimizing Print Speed and Image Band Setting* 5-6
- Reimaging Modified Fields* 5-7
- Optimizing Image Bands for Batch Printing* 5-7

#### **Using Test and Service Mode 5-8**

- Printing Test Labels* 5-10
- Using Data Line Print* 5-10
- Performing Selective Transfer* 5-11
- Using Memory Reset* 5-12

#### **Changing Configuration Commands in Test and Service Mode 5-13**

- Setting the Number of Dot Increments* 5-14
- Adjusting the Label Rest Point* 5-15
- Setting Emulation Mode* 5-17

#### **Replacing an 86XX, 4100, or 3400 Printer With a 3240 Printer 5-19**

- Differences Between 86XX Printers and 86XX Emulation* 5-19
  - No BEL Status Response* 5-19
  - Prints Erroneous Labels* 5-20
  - Limited User-Defined Protocol* 5-20
  - Added Auto-Transmit 3 and SI Configuration Commands* 5-22
  - Increased Storage Capacity* 5-22
  - Features Not Implemented* 5-22

*Differences Between the 3240 Printer and the 4100 Printer 5-23*  
    *DIP Switches 5-23*  
    *Communications 5-23*  
    *Entering Test and Service Mode 5-23*  
    *No Cutter 5-23*  
    *Front Panel 5-24*  
    *RAM Differences 5-24*  
*Differences Between the 3400 Printer and the 3240 Printer 5-24*  
    *Printhead Size 5-24*  
    *Fonts 5-25*  
    *DPI Emulation Modes 5-25*

## **A**

---

### **Printer Reference**

*3240 Printer Specifications A-3*  
*Factory Default Settings A-6*  
*Communications Protocol Characters A-7*  
*Configuration Parameters Upload A-8*  
*Printer Functional Boundaries A-9*  
*Printer Options A-11*  
*Bar Code Symbologies A-13*  
*International Character Sets A-16*  
*Extended Character Sets A-19*  
*DIP Switch Settings A-24*  
*Full ASCII Chart A-25*

## **B**

---

### **Cabling and Communications**

*Communications Reference B-3*  
*Interface Cables and Connectors B-11*  
*Connecting the Printer to a Network or Modem B-15*



**G**

---

***Glossary***

**I**

---

***Index***



## ***Before You Begin***

---

This section introduces you to standard warranty provisions, safety precautions, warnings and cautions, document formatting conventions, and sources of additional product information. A documentation roadmap is also provided to guide you in finding the appropriate information.

---

### ***Warranty Information***

To receive a copy of the standard warranty provision for this product, contact your local Intermec sales organization. In the U.S. call 1-800-755-5505, and in Canada call 1-800-688-7043. Otherwise, refer to the Worldwide Sales & Service list that came with this manual for the address and telephone number of your Intermec sales organization.

---

### ***Safety Summary***

Your safety is extremely important. Read and follow all warnings and cautions in this book before handling and operating Intermec equipment. You can be seriously injured, and equipment and data can be damaged if you do not follow the safety warnings and cautions.

**Do not repair or adjust alone** Do not repair or adjust energized equipment alone under any circumstances. Someone capable of providing first aid must always be present for your safety.

**First aid** Always obtain first aid or medical attention immediately after an injury. Never neglect an injury, no matter how slight it seems.

**Resuscitation** Begin resuscitation immediately if someone is injured and stops breathing. Any delay could result in death. To work on or near high voltage, you should be familiar with approved industrial first aid methods.

**Energized equipment** Never work on energized equipment unless authorized by a responsible authority. Energized electrical equipment is dangerous. Electrical shock from energized equipment can cause death. If you must perform authorized emergency work on energized equipment, be sure that you comply strictly with approved safety regulations.

---

## **Warnings and Cautions**

The warnings and cautions in this manual use the following format.



### **Warning**

*A warning alerts you of an operating procedure, practice, condition, or statement that must be strictly observed to avoid death or serious injury to the persons working on the equipment.*

### **Avertissement**

*Un avertissement vous avertit d'une procédure de fonctionnement, d'une méthode, d'un état ou d'un rapport qui doit être strictement respecté pour éviter l'occurrence de mort ou de blessures graves aux personnes manipulant l'équipement.*



### **Caution**

*A caution alerts you to an operating procedure, practice, condition, or statement that must be strictly observed to prevent equipment damage or destruction, or corruption or loss of data.*

### **Conseil**

*Une précaution vous avertit d'une procédure de fonctionnement, d'une méthode, d'un état ou d'un rapport qui doit être strictement respecté pour empêcher l'endommagement ou la destruction de l'équipement, ou l'altération ou la perte de données.*



---

## **About This Manual**

This manual contains all of the information necessary to install, operate, configure, design labels, troubleshoot, and maintain the printer.

This manual was written for analysts and programmers who operate, program, and connect the printer to a network or system. A basic understanding of DOS, programming, and data communications is necessary.

## **What You Will Find in This Manual**

This table summarizes the information in each chapter of this manual:

<b>For information on</b>	<b>Refer to</b>
Installing the printer	Chapter 1, "Getting Started." Tells you how to plug in the printer, load a small roll of media, configure the printer, and print a configuration test label.
Operating the printer	Chapter 2, "Operating the Printer." Explains the printer front panel, tells you how to load media for fanfold and self-strip applications, how to load ribbon, and how to test for communications.
Routine maintenance	Chapter 3, "Maintaining the Printer." Tells you how to maintain the printer.
Troubleshooting	Chapter 4, "Troubleshooting." Instructs you on how to clear error messages and troubleshoot programming or configuration problems. It also tells you how to control print quality.
Advanced procedures	Chapter 5, "Performing Advanced Procedures." Tells you how to perform advanced procedures on the 3240 printer such as decreasing processing time.
Printer specifications	Appendix A, "Printer Reference." Contains operating specifications, extended character sets, and reference tables.
Cabling and communication protocols	Appendix B, "Cabling and Communications." Provides information on correct cables and communication protocols for your system.

### **Terms and Conventions**

The following special terms and conventions occur throughout the manual. Refer to the glossary for a complete list of terms.

#### **Terms**

“Printer” or “3240” refer to the 3240 bar code label printer.

“Media” is the label stock on which the printer prints labels.

“Host” refers to a personal computer or other computer that communicates with the printer.

#### **Conventions**

The following conventions are used throughout this manual for operating procedures and descriptions of the printer.

- Feed/Pause refers to the Feed/Pause button on the printer front panel.
- Downloaded commands appear in the order that you enter them into the printer with the following conventions:

<b>Convention</b>	<b>Description</b>
< >	Angle brackets < > enclose mnemonic representations of ASCII control characters. For example, <ETX> represents the ASCII “End of Text” control character.
[ <i>data</i> ]	Italic text within brackets represents optional data.
<b>Ctrl</b>	Bold text represents a key on your keypad. For example, <b>Ctrl</b> represents the Ctrl key.
<b>Ctrl-C</b>	When two keys are joined with a dash, press them simultaneously. For example, if you see the command <b>Ctrl-C</b> , press the two keys at the same time.
E3 ; F3	Type all characters that appear in the Courier font by pressing an individual key on the keypad.



***Other Intermec Manuals***

The following manuals provide additional information about printing labels with your bar code printer.

<b>Manual</b>	<b>Intermec Part No.</b>
<i>Data Communications Reference Manual</i>	044737
<i>IPL Programming Reference Manual</i>	066396
<i>The Bar Code Book</i> by Roger C. Palmer	051241
<i>3240 Bar Code Label Printer Getting Started Guide</i>	063257
<i>9154 Multi-Drop Line Controller System Manual</i>	048517
<i>9161B Installation Manual</i>	049572
<i>9180 Network Controller User's Manual</i>	054292
<i>RF System User's Manual</i>	053574



**1**

***Getting Started***



*This chapter introduces the 3240 printer and explains how to get your new printer up and running for the first time.*

## ***Unpacking the 3240 Printer***

---

Remove the accessories, packing material, and the printer from the shipping container. Set the printer on a clean, stable, flat surface and remove the packing material. Save the shipping container and packing materials in case you need to move or ship your printer.

### ***Contents of the 3240 Printer Package***

---

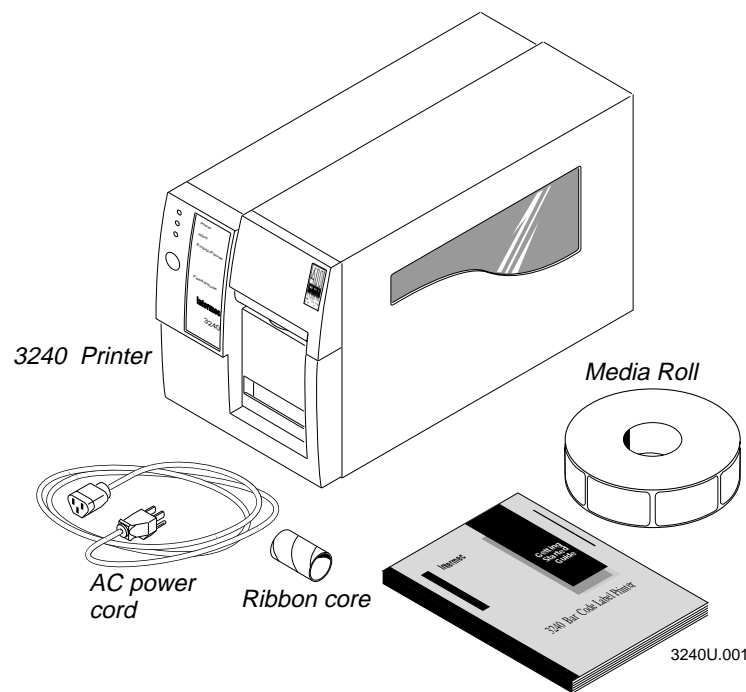

---

## ***Checking the Order for Completeness***

Verify the contents of the shipping container against the list below and the figure on the previous page. If any parts are missing, please contact your local Intermec representative.

- 3240 printer
- AC power cord
- Ribbon core
- *3240 Label Printer Getting Started Guide*
- Media roll (a 50-foot direct thermal media roll)

---

## ***Reporting Damage or Defects***

Intermec thoroughly tests and inspects your 3240 before shipping it from the factory. If you receive any items damaged, please take the following steps to correct the problem.

- Take photographs if necessary.
- Contact the transport carrier.

**Note:** *The customer is responsible for all damage claims against the carrier. See the "Intermec Terms of Sale" printed on your sales invoice.*

## Getting to Know Your 3240 Printer

---

Features of the 3240 printer include:

- Support for direct thermal and thermal transfer printing applications. Chapters 1 and 2 instruct you on how to load both types of media.
- An internal self-strip with integral liner takeup. See Chapter 2, “Operating the Printer,” for more information.
- Precision Print technology that produces high registration labels. See Chapter 4, “Troubleshooting,” for more information.
- Minimal supervision and maintenance.

Use the following figures to familiarize yourself with the 3240 printer.

---

### Front View

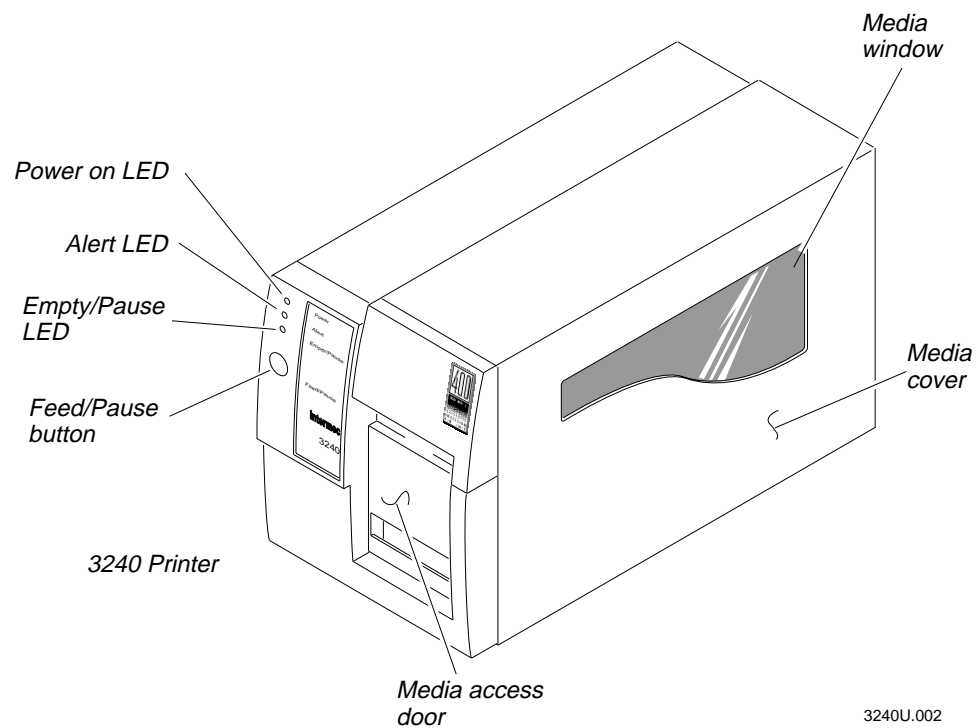

---

**Back View**

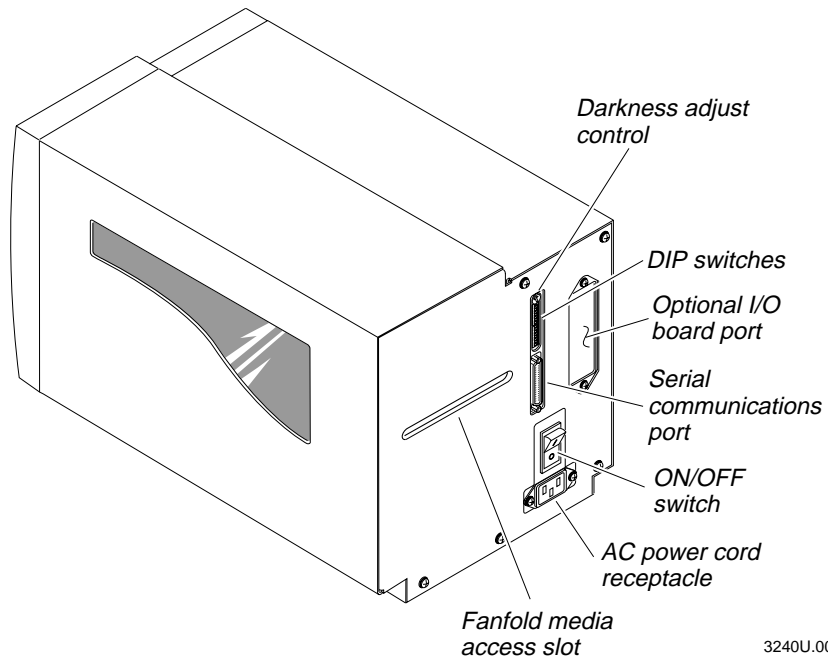

3240U.003

Several options are available for use with the 3240 printer. See Appendix A, "Printer Reference," for complete descriptions of these options.

## Preparing the Printer for Installation

Before connecting your 3240 to your data collection system, you need to:

- plug in your printer.
- open the printer and load media.
- print a configuration test label.

### Plugging In the Printer

The back of the 3240 printer contains the AC power cord receptacle, the serial communications port, the (I/O) switch, and two banks of DIP switches.

To plug in the printer

1. Turn the switch to the off (O) position.
2. Make sure you set the DIP switches to their factory default settings.

**Top Bank** Set switch 1 on. Set switches 2 through 8 off.

**Bottom Bank** Set switches 1 through 8 off.

For a description of the DIP switch settings, see “Configuring the Serial Port” later in this chapter.

3. Plug the AC power cord into the receptacle at the back of the printer.

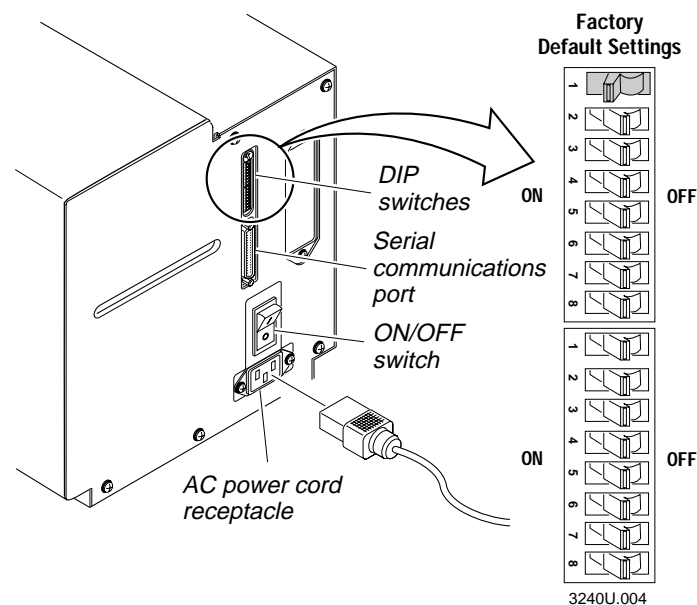

4. Plug the other end of the power cord into a grounded wall outlet or surge protector.
5. Set the ON/OFF switch to the on (|) position. The Power On LED lights, the Empty/Pause LED flashes, and the printer (platen roller) advances. The Empty/Pause LED stays lit because you have not loaded media yet.

---

## ***Opening the Printer***

You need to open the printer every time you load media or perform maintenance procedures.

### **To open the printer**

1. Place the fingers of your right hand between the two notches on the lower edge of the media cover (the media cover release) and pull the bottom of the media cover away from the base of the printer.
2. Grasp the front of the media cover with your left hand and lift the front of the media cover upward to release it from the printer frame.
3. Lift the media cover away from the top of the printer.

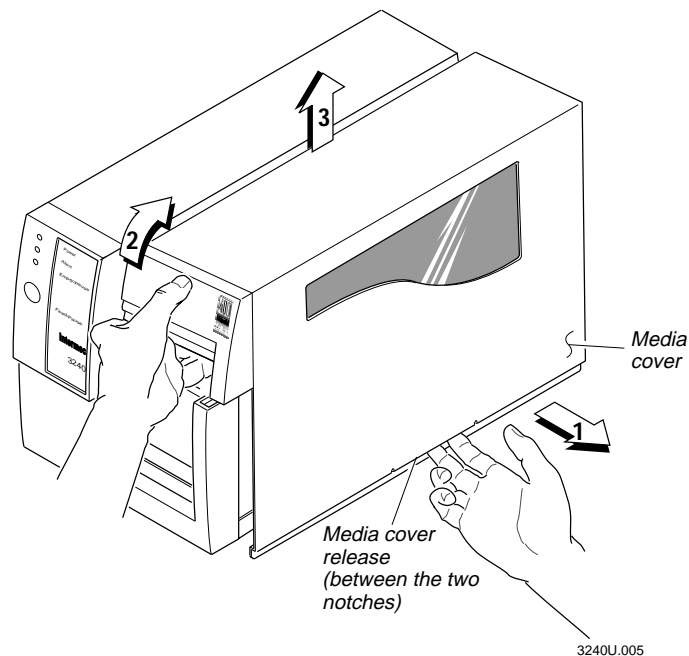

3240U.005

---

## **Loading a Roll of Media**

In straight-through printing, you load a roll of media on the supply roll post and feed it straight through the printer mechanism and out the front of the printer. As the 3240 prints individual labels, you can remove them from the roll by pulling them down across the tear bar. Use the small roll of media that came with the printer to perform this procedure.

**Note:** *This procedure covers how to load media for straight-through print mode using a roll of direct thermal or thermal transfer label media. The default setting for the printer is direct thermal mode.*

**Note:** *Attached to the media bag is a small label with a three-digit sensitivity number printed on it. Make sure you save this label. You need this information to set the correct media sensitivity number. See “Setting the Media Sensitivity Number” in Chapter 2 for more information.*

### **To load the media**

1. Open the printer.
2. Raise the printhead by rotating the head lift lever clockwise to release it.
3. Turn the supply roll retainer counterclockwise to release it and slide it to the outer end of the supply roll post. Turn it clockwise to lock it in place.  
  
*Note: You do not need to perform this step when replenishing media of the same width.*
4. Lift the media brake up and slide it towards the front of the printer until it reaches its resting position.
5. Place the media roll on the supply roll post and position it firmly against the inside wall of the printer.
6. Lift up on the media brake, slide it toward the back of the printer, and lower it onto the media roll.
7. Turn the supply roll retainer counterclockwise and slide it up to the edge of the media roll. Turn the supply roll retainer clockwise to secure.

**Note:** *If you are using a narrow roll of media (less than 1 inch), insert the media support between the roll of media and the supply roll retainer before you secure it in place.*

---

**Loading Media Into the 3240 Printer**

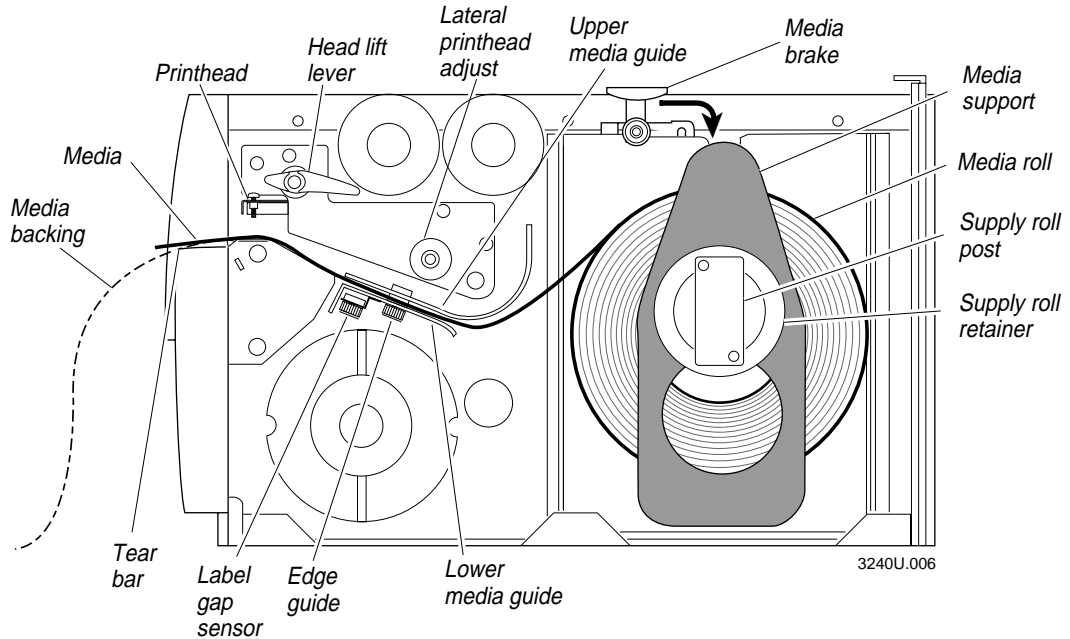

8. Unscrew the edge guide and slide it all the way to the outer edge of the lower media guide. Screw it in place.

**Note:** If you are replacing the empty media roll with a new roll of the same width, you do not need to adjust the edge guide or the supply roll retainer.

9. Pull down on the lower media guide to allow access to the media path.
10. Unroll several inches of media and insert it between the two media guides and out the front of the printer. Release the lower media guide.
11. If you are using thermal transfer media, you need to load ribbon now. For help, see “Loading Thermal Transfer Ribbon” in Chapter 2.
12. Rotate the head lift lever counterclockwise until it locks in place.
13. Press the Feed/Pause button until the printer feeds out approximately 6 inches of media.
14. Unscrew the edge guide and slide it inward until it touches the edge of the media. Screw it in place.

**Note:** Adjust the label gap sensor if you are using narrow media (less than 1 inch wide). For help, see “Accurately Detecting the Start of a Label” in Chapter 4.

15. If you are loading continuous media or mark label stock, use PrintSet, your third-party software or the printer command set to tell the printer what kind of media you are using.
16. Press Feed/Pause to advance several inches of media through the printer and out the label opening in the front cover. Your printer is now ready to print labels.

**Note:** Refer to the label located on the inside of the media cover for directions on loading media. For your convenience, you may want to refer to it when loading media in the future.

**Note:** If you are loading narrow media (1 inch or less) you need to adjust the bias adjust screw to achieve the highest print quality. For help, see “Correcting Uneven Print Quality,” in Chapter 4.

---

## **Printing the Hardware Configuration Test Label**

Now that you have loaded media in the printer, you are ready to print the hardware configuration test label. Use this label for reference when installing your 3240 printer and for verifying proper printer operation.

### **To print the hardware configuration test label**

1. Turn the ON/OFF switch to the off position.
2. Press and hold the Feed/Pause button while turning the printer power on. The Alert and Empty/Pause LEDs blink during the printer self-test.
3. Release the Feed/Pause button when the media starts moving. The printer feeds out one or two blank labels (to verify the label length) and then prints the hardware configuration test label.
4. Turn the printer power off and then on to enter Print mode.

**Note:** For the entire hardware configuration label to print out, you must use media that is at least 2.6 inches wide.

---

## **3240 Hardware Configuration Test Label**

<b>3240 Hardware Configuration</b>	
Memory Installed	
Storage RAM	: 128 kilobytes
Image RAM	: 375 kilobytes
Flash RAM	: none
Mileage	
Inches Processed	: 36
Inches Burned	: 12
Printhead	
Width	: 1024 dots
Dot Size	: 2.5 mil
Burn Pot Setting	: 231
Hardware Options	
I/O Option	: none
Internal Option	: none
External Option	: Self Strip
Firmware Checksum	
ROM0 (U9)	: CDE3 ROM1 (U8): 0A1E
Program	: 063103      VERSION: 0.9

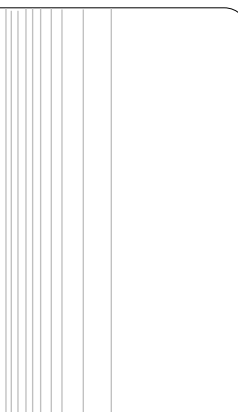

3240U.007

### **What the Hardware Configuration Test Label Tells You**

The hardware test label provides statistics on:

- the amount of installed memory.
- the amount of media printed.
- the printhead configuration.
- the program and version numbers.

### **If the Hardware Configuration Test Label Does Not Print**

If you are unable to print a hardware configuration test label, please refer to Chapter 4, “Troubleshooting,” for help.

## **Connecting the Printer to Your System**

---

You can connect your 3240 printer to a PC, a local area network, an AS/400 (or other midrange), or a mainframe. This section tells you how to connect your printer to any of these systems.

This illustration shows you where to connect your system to the printer. You can use either of these two ports on the back of the printer:

- Serial communications port
- Optional I/O board port (if you have an adapter card installed)

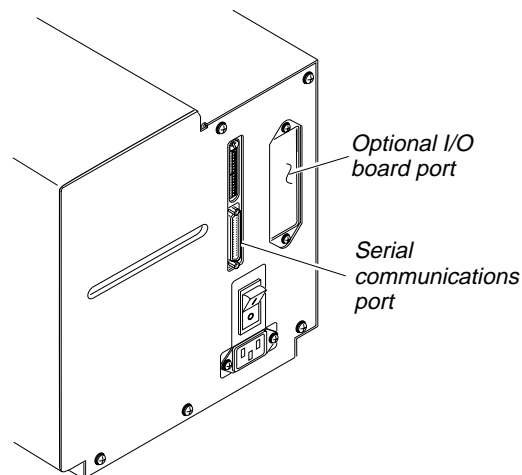

3240U.011

---

## **Connecting the 3240 to a PC**

You can connect the 3240 to either a serial port or parallel port (if you have the option installed) on your PC. You must provide the correct cables for connecting the printer. Refer to the following instructions for cable information. Contact your Intermec representative for ordering assistance if you do not have the appropriate cables.

### **Connecting the Printer to a PC Serial Port**

To connect the 3240 to your PC serial port, you need a shielded EIA RS-232, RS-422, or RS-485 electrical interface with a 25-pin D-style subminiature connector. It must have pins on the printer end and an appropriate serial port connector on the other end.

Use the following table to determine the correct Intermec cable for your application.

<b>For Connecting To</b>	<b>Use Intermec Cable Part Number</b>
IBM PC AT	048693 (25-pin printer to 9-pin serial port straight-through)
IBM PC XT	048668 (25-pin printer to 25-pin serial port null modem)

### **To connect your printer to a PC serial port**

1. Turn the ON/OFF switch to the off position.
2. Plug the 25-pin connector into the serial communications port on the back of the 3240 printer.
3. Plug the other end of the cable into a serial COM port on the PC.
4. If necessary, change the PC serial port configuration to match your printer. The default configuration settings for the 3240 printer are:
  - 9600 baud
  - even parity
  - 7 bit word length
  - XON/XOFF no status response protocol
  - device address A
  - direct thermal media

See "Configuring the Serial Port" later in this chapter for more information.

### ***Connecting the Printer to a PC Parallel Port***

If you are using a parallel port to communicate with the printer, you need:

- a Centronics interface adapter installed in the printer.
- a parallel cable to run between the printer and the PC.

If you did not have the parallel interface installed at the factory, you can install the field installable option (Intermec Part No. 056830) in the optional I/O board port of your printer. You can purchase a parallel cable from Intermec (Part No. 051211) or from your local computer store.

#### **To connect your printer to a PC parallel port**

1. Turn the ON/OFF switch to the off position.
2. Plug the Centronics cable connector into the interface adapter port on the back of the 3240 printer.
3. Plug the other end of the cable into a parallel port on the PC.

---

### ***Connecting the 3240 to a Network***

You can connect the 3240 printer to Novell NetWare networks, Token Ring networks, or TCP/IP networks. To connect the 3240 printer to a network, you must have:

- a Centronics parallel interface installed in your printer.
- a network interface adapter (for example, Ethernet).

If you did not have the interface installed at the factory, you can install the field installable option (Intermec Part No. 056830) in the optional I/O board port of your printer.

The network interface adapter (for example, Ethernet) connects to the Centronics parallel interface on the back of the printer. Your network must be able to use XON/XOFF (hardware handshake) protocol. Refer to your network documentation for more information.

---

### ***Connecting the 3240 to an AS/400***

To connect a 3240 printer directly to an AS/400 or midrange system, you need:

- a twinax adapter card.
- a twinaxial cable equivalent to IBM part number 7362267 or 7362062.  
The maximum cable length for the twinax interface is 5000 feet (1525 meters).

If you did not have the twinax card installed at the factory, you can install the field installable option (Intermec Part No. 056835) in the optional I/O board port of your printer.

For help on cabling and communications, see the manual that comes with the twinax adapter card.

*Note: If you are using a midrange computer other than the AS/400, refer to your system documentation for information on cabling and setting up communications.*

---

### ***Connecting the 3240 to a Mainframe***

To connect a 3240 printer directly to an IBM mainframe, you need:

- a coax adapter card.
- a coaxial cable equivalent to IBM part number 2577672 or 1833108.

The maximum cable length allowed is 4920 feet (1500 meters). See the IBM specification *Installation and Assembly of Coaxial Cable and Accessories*, part number GA27-2805-4, for further information.

If you did not have the coax card installed at the factory, you can install the field installable option (Intermec Part No. 056836) in the optional I/O board port of your printer.

For help on cabling and communications, see the manual that comes with your coax adapter card.

## ***Configuring the Serial Port***

---

You need to configure the serial port of the 3240 printer to match the configuration of your PC or network controlling device. If the printer's default settings do not match, use the DIP switch settings table to configure the serial port.

In addition to the familiar parameters that you need to configure (such as baud rate and parity), you also need to set the protocol and device address. The protocol is the type of network you use to connect the printer, the host, and the rest of the data collection system. Intermec protocol includes Standard, Polling Mode D, and Multi-Drop protocol. You need to assign a unique device address for each device connected to the Multi-Drop protocol.

### **To configure the printer serial port**

1. Use the DIP Switch Settings table to locate the DIP switches you need to change to correctly configure the serial port.
2. Use a small straight-slot screwdriver to set the appropriate DIP switches on or off.

For example, if you want to change the media type to thermal transfer, set DIP switch 8 on the bottom bank of switches to the ON position.

3. Turn the printer power off and then on for the configuration changes to take effect.

**Note:** Ignore Multi-Drop switches if you are not using a Multi-Drop network.

DIP Switch Settings

Top Bank Switch Number

	1	2	3	4	5	6	7	8
OFF								
ON								
O = OFF								
1 = ON								
<b>Baud Rate Selection</b>								
19,200	0	0	0					
9,600*	1	0	0					
4,800	0	1	0					
2,400	1	1	0					
1,200	0	0	1					
reserved	1	0	1					
reserved	0	1	1					
reserved	1	1	1					
<b>Parity Selection</b>								
Even*						0	0	
Odd						1	0	
None						0	1	
None						1	1	
<b>Number of Data Bits</b>								
7 Bit								0
8 Bit								1
<b>Reserved</b>								
								0 0

Default settings are noted with an \*

Bottom Bank Switch Number

	1	2	3	4	5	6	7	8
OFF								
ON								
O = OFF								
1 = ON								
<b>Multi-Drop Address Selection</b>								
*A	0	0	0	0	0			
B	1	0	0	0	0			
C	0	1	0	0	0			
D	1	1	0	0	0			
E	0	0	1	0	0			
F	1	0	1	0	0			
G	0	1	1	0	0			
H	1	1	1	0	0			
I	0	0	0	1	0			
J	1	0	0	1	0			
K	0	1	0	1	0			
L	1	1	0	1	0			
M	0	0	1	1	0			
N	1	0	1	1	0			
O	0	1	1	1	0			
P	1	1	1	1	0			
Q	0	0	0	0	1			
R	1	0	0	0	1			
S	0	1	0	0	1			
T	1	1	0	0	1			
U	0	0	1	0	1			
V	1	0	1	0	1			
W	0	1	1	0	1			
X	1	1	1	0	1			
Y	0	0	0	1	1			
Z	1	0	0	1	1			
0	0	1	0	1	1			
1	1	1	0	1	1			
2	0	0	1	1	1			
3	1	0	1	1	1			
4	0	1	1	1	1			
5	1	1	1	1	1			
<b>Protocol Selection</b>								
XON/XOFF*								0
Intermec Protocols								1
<b>XON/XOFF Selection</b>								
No Status Response*								0
With Status Response								1
<b>DT/ITR</b>								
Direct Thermal*								0
Thermal Transfer								1

Default settings are noted with an \*

3240U.008

## ***Verifying Printer Communications With Your System***

---

After connecting the printer to your system, you need to test communications. The easiest way to test communications is to set the printer to Data Line Print mode, which is part of Test and Service mode, and send a character string down from your system.

If you have just printed a configuration test label, you are already in Data Line Print mode. Start the following procedure with Step 4.

**Note:** *Make sure that your cabling is correct. See Appendix B, “Cabling and Communications,” for more information. If your cabling is not correct, you may receive a write fault error.*

### **To verify communications with your system**

1. Turn the ON/OFF switch to the off position.
2. Press and hold the Feed/Pause button while you turn the ON/OFF switch to the on position. The printer prints out the hardware configuration test label.
3. Release the Feed/Pause button. You are now in Data Line Print mode.
4. Transmit at least four characters from your system.

At this point the printer does not attempt to interpret any printer commands, but simply prints each character with its hexadecimal equivalent underneath.

5. To enter normal Print mode, turn the printer power off and then on again.

If this procedure does not work, make sure that the DIP switches match the serial port configuration of the system. Make sure you have the printer cable securely plugged into the correct port of your system.



2

## ***Operating the Printer***



*Use this chapter to understand how to use the printer front panel, load fanfold media and media for self-strip printing, set the media sensitivity number, and communicate with the printer.*

## ***Learning How to Operate the Printer***

---

To operate the printer, you need to understand:

**Front panel** LEDs help you monitor the status of the printer. The Feed/Pause button performs various tasks.

**Loading media and ribbon** Explains how to load fanfold media, thermal transfer ribbon, and the procedure for using the self-strip option.

**Media sensitivity numbers** Optimizes print quality and print speed.

**Communicating with the printer** Explains different methods for transferring information from the host to the printer and from the printer to the host.

## ***Understanding the Front Panel***

---

On the front panel of the 3240 printer, you will find one button and three light emitting diodes (LEDs).

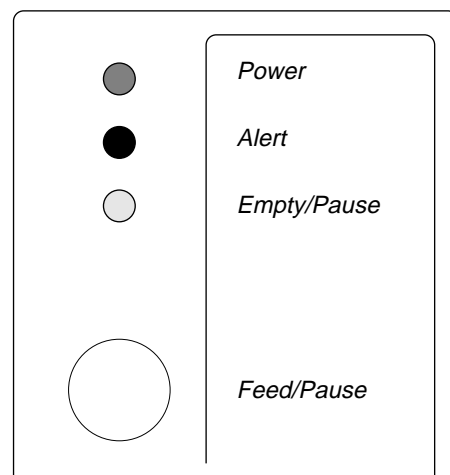

3240U.015

## Using the Front Panel LEDs

You use the front panel LEDs to monitor the status of the printer:

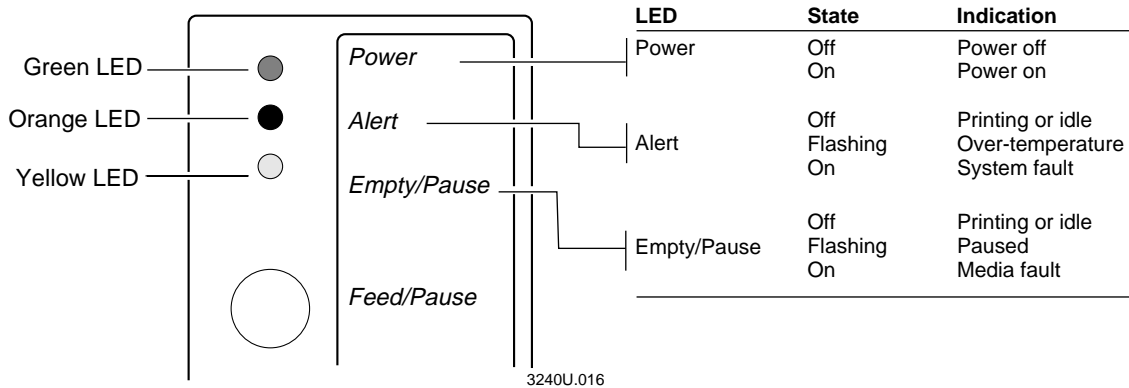

## Using the Front Panel LEDs for Troubleshooting

**Over-temperature** If the printer overheats, the Alert LED flashes and the printer stops. Do not try to troubleshoot or adjust the printer—just allow it enough time to cool down and it will resume operation on its own.

**Media or system faults** If the Empty/Pause or the Alert LED remains on, your printer is experiencing a media or system fault. See Chapter 4, “Troubleshooting,” for information on correcting the problem.

## ***Using the Feed/Pause Button***

The Feed/Pause button, located on the front panel of the 3240 printer, performs several functions depending on the mode of the printer.

<b>The Printer Is</b>	<b>You Want To</b>	<b>What to Do</b>
Idle	Feed out one label or a minimum specified amount of media.  Continuously feed media.  Take the printer offline.	Press and release the Feed/Pause button.  Press and hold the Feed/Pause button. When you release the button, the media stops feeding.  Press the Feed/Pause button twice. Press the button again to bring the printer online.
Printing	Pause the printer.  Cancel the current print job.	Press and release the Feed/Pause button. Press and release the button again to resume printing.  Press and hold the Feed/Pause button until the printer stops printing.
Powered on for the first time	Print the hardware configuration label.	Press and hold the Feed/Pause button. See “Printing the Hardware Configuration Test Label” in Chapter 1 for more information.

## **Loading Media Into the Printer**

---

You can load media into the 3240 printer in three different ways:

- Fanfold printing
- Self-strip printing with roll media
- Straight-through printing with roll media (see Chapter 1)

You can load media with the printer power turned on or off. The following procedures for loading media assume that the ON/OFF switch is turned on.

---

### **Loading Media for Fanfold Printing**

For fanfold printing, you place a stack of fanfold media at the rear of the printer and feed it into the printer through the fanfold media access slot.

*Note: The top of the stack of media has a three-digit sensitivity number printed on it. You need this information to set the correct media sensitivity number. Refer to "Setting the Media Sensitivity Number" later in this chapter for more information.*

#### **To load media for fanfold printing**

1. Open the printer.
2. Rotate the head lift lever clockwise to release the printhead.
3. Turn the supply roll retainer counterclockwise and slide it to the outer end of the supply roll post. Turn it clockwise to lock it in place.
4. Lift the media brake up and slide it toward the front of the printer until it reaches its resting position.
5. Place the box of fanfold media slightly lower than the slot in the printer back cover and line it up with the label path through the printer.
6. Unscrew the edge guide and slide it to the outer edge of the lower media guide and screw it in place.
7. Pull down on the lower media guide to allow access to the media path.
8. Insert the fanfold media through the printer mechanism as shown in the illustration. Release the lower media guide.
9. Lift up on the media brake, slide it toward the back of the printer, and lower it onto the media.

---

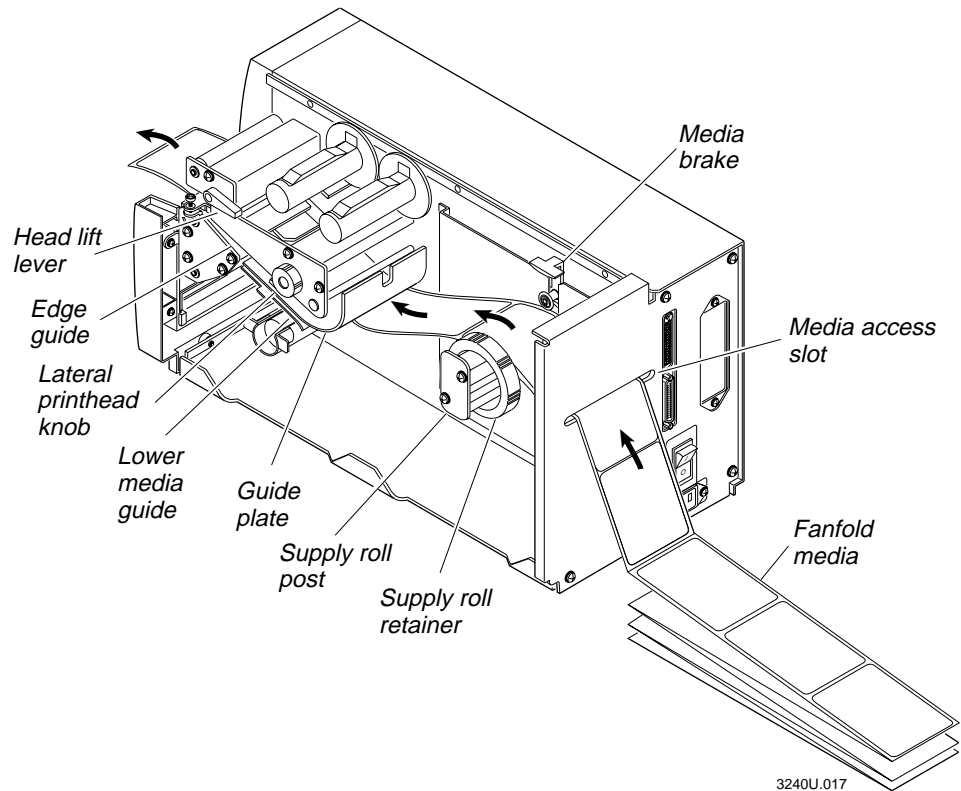
**Loading Fanfold Media for Straight Through Printing**

3240U.017

10. Slide the supply roll retainer up to the edge of the fanfold media and turn the supply roll retainer clockwise until it locks firmly in place.
11. Rotate the head lift lever counterclockwise until it locks.
12. Press the Feed/Pause button until the printer feeds out approximately 6 inches of media.
13. Unscrew the edge guide and slide it inward until it just touches the edge of the media. Screw it in place.
14. Replace the media cover. The printer is now ready to print the configuration test label.

**Note:** If the yellow Empty/Pause LED does not go out, reload the media and try again.

---

## **Loading Media for Self-Strip Printing**

Use self-strip printing in applications where you want to apply labels to a surface immediately. After printing a label, the printer prints out the label with the backing removed. The rewinder hub collects the backing after passing over the self-strip assist roller. The rewinder hub can hold the backing from an entire roll of media.

**Note:** Attached to the media roll is a small label with a three-digit sensitivity number printed on it. Make sure you save this label. You need this information to set the correct media sensitivity number. Refer to “Setting the Media Sensitivity Number” later in this chapter for more information.

**Note:** If you lift the printhead while printing with self-strip, you may not receive the best performance from the Precision Print technology. If you must lift the printhead, remove accumulated liner from the takeup hub before resuming print.

### **To load self-strip media**

1. Open the printer.
2. Raise the printhead by rotating the head lift lever clockwise to release it.
3. Turn the supply roll retainer counterclockwise to release it and slide it to the outer end of the supply roll post. Turn it clockwise to lock it in place.
4. Lift the media brake up and slide it toward the front of the printer until it reaches its resting position.
5. Place the media roll on the supply roll post and position it firmly against the inside wall of the printer.
6. Lift up on the media brake, slide it toward the back of the printer, and lower it onto the media roll.
7. Turn the supply roll retainer counterclockwise and slide it up to the edge of the media roll. Turn the supply roll retainer clockwise to secure.

**Note:** If you are using a narrow roll of media (less than 1 inch), insert the media support between the roll of media and the supply roll retainer before securing it.

8. Unscrew the edge guide and slide it to the outer edge of the lower media guide. Screw it in place.
9. Pull down on the lower media guide to allow access to the media path.

**Note:** If you are replacing the empty media roll with a new roll of the same width, you do not need to adjust the edge guide.

10. Unroll several inches of media and insert it between the media guides and out the front of the printer. Release the lower media guide.

---

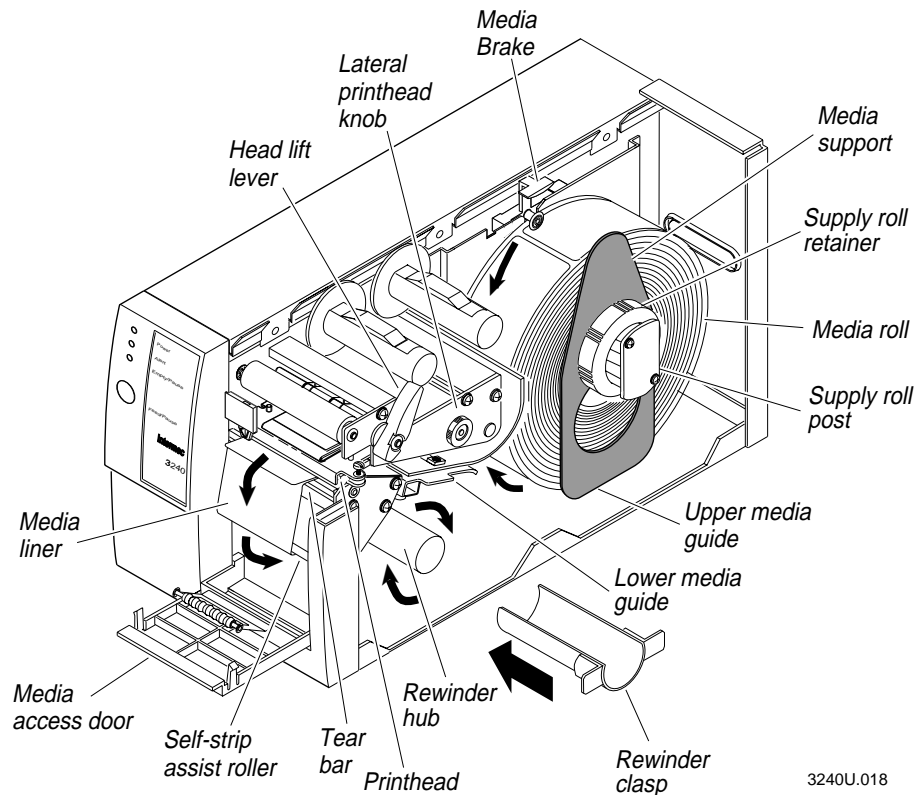
**Loading Media for Self-Strip Printing**

11. Pull out 10 to 12 inches of media and remove the exposed labels from the media liner.
12. Open the media access door and thread the media liner under the self-strip assist roller and over the rewinder hub in a clockwise direction.
13. Remove the rewinder clasp from the rewinder hub and wind approximately 2 inches of media liner over the rewinder hub.
14. Secure the media by snapping the rewinder clasp onto the rewinder hub. Turn the rewinder hub clockwise to remove all slack from the media liner between the tear bar and the rewinder hub.
15. Close the media access door.
16. Use your third-party software or the printer command set to enable self-strip and the label taken sensor. A DOS example follows this procedure.

**Note:** See “Adjusting the Printer for Self-Strip Printing,” in Chapter 4 for information on how to position the label taken sensor.

17. Press Feed/Pause to advance a label through the printer. Remove the exposed label from the front of the printer.
18. Unscrew the edge guide and slide it inward until it just touches the edge of the media. Screw it in place.

*Note: Adjust the label gap sensor if you are using narrow media (less than 1 inch wide). See "Accurately Detecting the Start of a Label" in Chapter 4.*

19. Replace the printer cover. The printer is now ready to print labels.

## Loading Thermal Transfer Ribbon

---

If you plan to use thermal transfer media, you must install a thermal transfer ribbon (TTR) to print in thermal transfer mode.

*Note: Save the plastic bag that your ribbon comes in. Attached to the ribbon bag is a small label with a three-digit sensitivity number printed on it. You need this information to set the correct media sensitivity number. Refer to “Setting the Media Sensitivity Number” later in this chapter for more information.*

### To load thermal transfer ribbon

1. Make sure the printhead is in the raised position. If not, turn the head lift lever clockwise until it releases the printhead.
2. Place the empty ribbon core that comes with the printer onto the ribbon rewind hub.
3. Detach the leader from the new thermal transfer ribbon roll and unwind the end of the ribbon approximately 8 inches. The edge of the ribbon has a leader (with an adhesive strip on the leader edge) to guide the ribbon through the printhead mechanism.
4. Slide the roll of thermal transfer ribbon onto the ribbon supply hub with the ribbon roll winding clockwise.
5. Route the ribbon leader through the printer mechanism as shown in the following illustration.

*Note: Make sure that the ribbon goes over the label gap sensor PCB located on the top of the upper media guide. If the ribbon becomes caught on the PCB, it can cause the ribbon to wrinkle.*

6. Attach the leader from the new thermal transfer ribbon roll to the empty ribbon core using the adhesive strip on the leader edge.

*Note: Make sure the ribbon runs above the upper media guide. The shiny side of the ribbon must come in contact with the printhead.*

7. Wind the ribbon rewind hub clockwise until the ribbon runs smoothly through the printhead mechanism.

---

**Loading Thermal Transfer Ribbon**

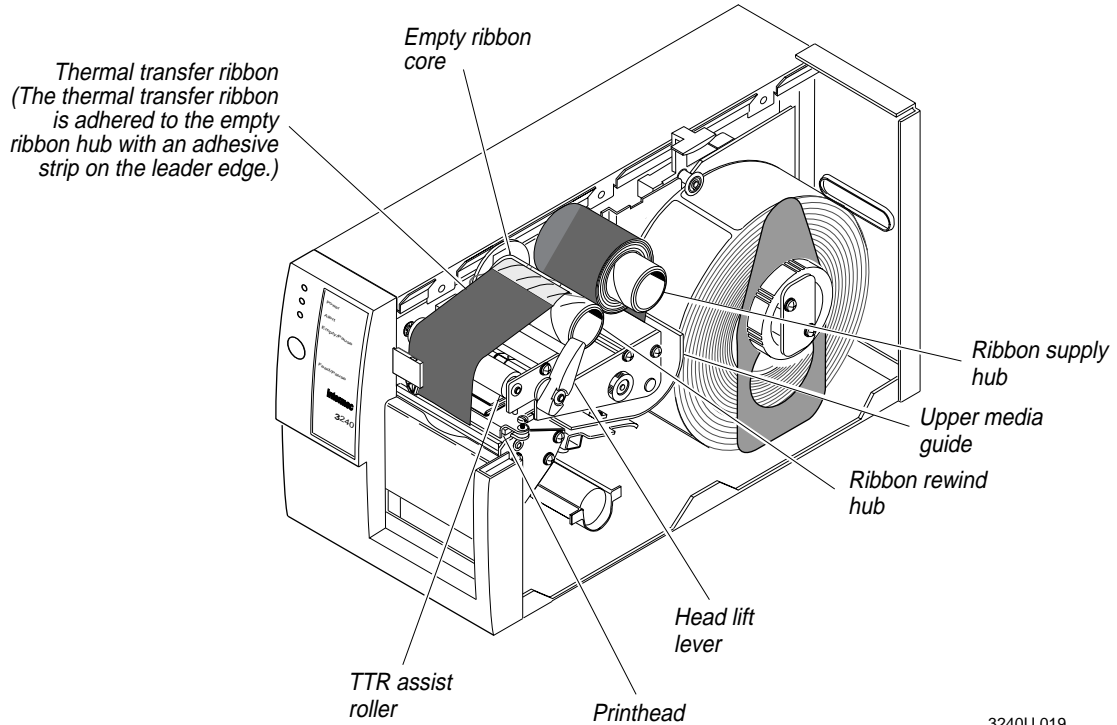

8. Engage the printhead by rotating the head lift lever counterclockwise until it locks.
9. To enable thermal transfer printing, set DIP switch 8 on the bottom bank of switches to the on position. For help, see “Configuring the Serial Port” in Chapter 1.
10. Press the Feed/Pause button to advance the ribbon through the printer. The printer is now ready to print.

**Note:** When replacing the thermal transfer ribbon roll in the future, use the empty ribbon supply core as the new rewinder core.

## Setting the Media Sensitivity Number

---

Media sensitivity is important because you use it to optimize print quality and print speed. The three-digit sensitivity number specifies the amount of heat required by the printhead to image a label. The amount of heat that each roll of media or ribbon requires is unique due to different chemistries and manufacturing processes.

Intermec has developed heating schedules (the amount of heat required to image a label) to produce the highest possible print quality for Intermec media and ribbon combinations on Intermec printers. You will find a small label with a three-digit sensitivity number attached to the packaging of each Intermec media and ribbon product. Use this three-digit number to optimize print quality and print speed on the 3240 printer. You can only achieve the best print quality on the 3240 printer by using Intermec ribbon and media products.

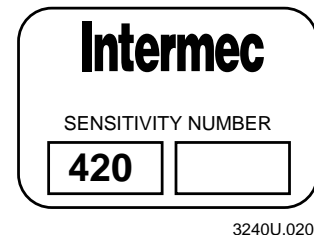

The 3240 default setting for direct thermal media sensitivity is 420. For thermal transfer media, the default setting is 567. Use the packaging that you saved, when loading media and ribbon, to determine the correct sensitivity number. Use your third-party software or the printer command set to set the media sensitivity number. For help on how to set the media sensitivity number, see the DOS example in the next section. If you want to see the current sensitivity setting of your 3240, print out a software configuration label.

### To print a software configuration label

1. Turn off the printer.
2. Press and hold the Feed/Pause button while turning the printer on.  
The printer prints out a hardware configuration label and then enters Data Line Print mode.
3. Set the DIP switches to print out the software test label.  
**Top Bank** Set switches 1 through 6 and 8 off. Set switch 7 on.  
**Bottom Bank** Set switches 1 through 8 off.
4. Hold the Feed/Pause button down for 1 second. The printer prints out the software configuration label.
5. Exit Test and Service mode by turning the printer power off and then on.
6. Return the DIP switches to their original settings.

## **Setting the Media Sensitivity Number for Intermec Media and Ribbon**

The sensitivity number on each roll of thermal transfer media or ribbon has an asterisk (\*) in place of one of the digits. To optimize the sensitivity number for thermal transfer media, you combine the digits as in this example.

<b>Media or Ribbon</b>	<b>Sensitivity Rating</b>	<b>Description</b>
Thermal Transfer Media	56*	The asterisk reserves the third digit to identify the ribbon's sensitivity number.
Thermal Transfer Ribbon	5*7	The asterisk reserves the second digit to identify the media's sensitivity number.
-----		
	567	Optimum Sensitivity Rating

To set the sensitivity rating for direct thermal media, use the three-digit sensitivity rating located on the roll of media or listed in the Direct Thermal Media Sensitivity Settings table on the following page.

### **To change the media sensitivity number with PrintSet**

1. Start the PrintSet applications
2. Click the Paper type button:



3. In the Print Quality Setup dialog box, enter your three-digit number in the Media Sensitivity Number field.
4. Click OK.

---

## ***Setting the Media Sensitivity Number for Other Media and Ribbon***

If you are not using Intermec media and ribbon, or you misplaced your packaging with the three-digit sensitivity number label on it, you can set the approximate sensitivity rating. The first column of the Direct Thermal and Thermal Transfer Media and ribbon tables list the approximate sensitivity settings. To achieve acceptable print quality, enter the three-digit media sensitivity number (for example, 800).

If you are unsure of how to set the media sensitivity rating, start with the highest setting, which provides the lowest energy (800 for thermal transfer and 700 for direct thermal), and work your way down until you achieve the best print quality.

---

### ***Direct Thermal Media Sensitivity Settings***

<b>Approximate Sensitivity Ratings</b>	<b>Sensitivity Setting</b>	<b>Direct Thermal Media</b>
<b>700 Series High Sensitivity</b>	720	Duratherm Lightning Plus
	700	Duratherm Lightning IR-2
<b>400 Series Medium Sensitivity</b>	480	Duratherm Lightning IR-2
	460	European IR
	450	Duratherm Lightning-1
	440	European Thermal
	420	Duratherm Lightning-2
<b>100 Series Low Sensitivity</b>	170	European Tag
	170	European Reinforced
	160	Duratherm II Tag
	140	European Top
	130	Duratherm II

---

***Thermal Transfer Media and Ribbon Sensitivity Settings***

<b>Approximate Sensitivity Ratings</b>	<b>Sensitivity Setting</b>	<b>Direct Thermal Media</b>
<b>800 Series High Sensitivity (Paper)</b>	864	European Uncoated/Standard
<b>600 Series Medium Sensitivity (Plastic)</b>	687	Duratran TTR Polyimide (Valeron)/Premium
	633	European Polyethelene/Premium
	627	Duratran Kimdura/Premium
<b>500 Series Medium Sensitivity (Paper)</b>	567	Duratran II/Premium
	527	Duratran II Tag-5 mil/Premium
	527	Duratran II Tag-7 mil/Premium
	513	European Board Tag/Premium
	513	European Coated/Premium
<b>300 Series Low Sensitivity (Plastic)</b>	369	Super Premium Kimdura/Super Premium 2
	369	Super Premium Polyimide/Super Premium 2
	366	Super Premium Kimdura/ Super Premium 1
	366	Super Premium Polyimide/Super Premium 1
<b>200 Series Low Sensitivity (Plastic)</b>	222	Glossy Polyimide (Kapton)/Super Premium 3
	226	Glossy Polyimide (Kapton)/Super Premium 1
	236	Matte Polyimide (Kapton)/Super Premium 1
	238	Matte Polyimide (Kapton)/Super Premium 4

## ***Communicating With the Printer***

---

You are now ready to print labels by downloading data from the host to the 3240 printer. *Downloading* is the universal term used to describe the transfer of information from the host to any connected peripheral device, such as the 3240 printer. When you transfer data from your printer to the host, you are performing a process called *uploading*.

You can use several methods to download information in your data collection system. The next sections describe different ways to communicate with the printer.

---

### ***Using the PrintSet Software***

Use the PrintSet application software to easily configure your printer from your PC. You can upload the current configuration settings, modify them, and then download them to the 3240 printer. PrintSet also lets you:

- download graphics and fonts (including TrueType).
- print test labels.
- allocate memory.
- download configuration files.

For help using PrintSet, refer to the online help portion of the application software.

---

### ***Using Third-Party Software***

You can use third-party software to set many of the printer parameters. You can configure the parameters that your software does not set by using the printer command set or the configuration DIP switches.

Use your third-party software to create label formats and convert graphics into a user-defined character (UDC) format that the 3240 printer can interpret. Refer to your third-party documentation and the *IPL Programming Reference Manual* for more information.

---

### ***Using the Intermec Printer Language (IPL) Commands***

You can also create labels by downloading formats (designs) and data you create with IPL commands. You can use the printer to perform any function or activate any feature of the 3240 printer except for those features or functions that you set with the DIP switches.

**Note:** For help using IPL commands, see the *IPL Programming Reference Manual*.

---

## **Printing a Test Label**

If you would like to test your communications by downloading a label, follow the example below. Use the PrintSet application software to send a test label to the printer.

### **To print the test label**

1. Start PrintSet on your PC.
2. From the Options menu, click Test Print.
3. Select the Test Label option button.
4. Select either the Test or the Bar Code option button.

If you select to print text, you can choose a font in the Select Printer Font list box.

If you select to print a bar code, you can choose a symbology in the Select Symbologies list box.

5. Click on the Print button. Your 3240 printer prints out a test label.

For example, if you chose to print a bar code with the Code 39 symbology, your printer prints out a label similar to the test label below:

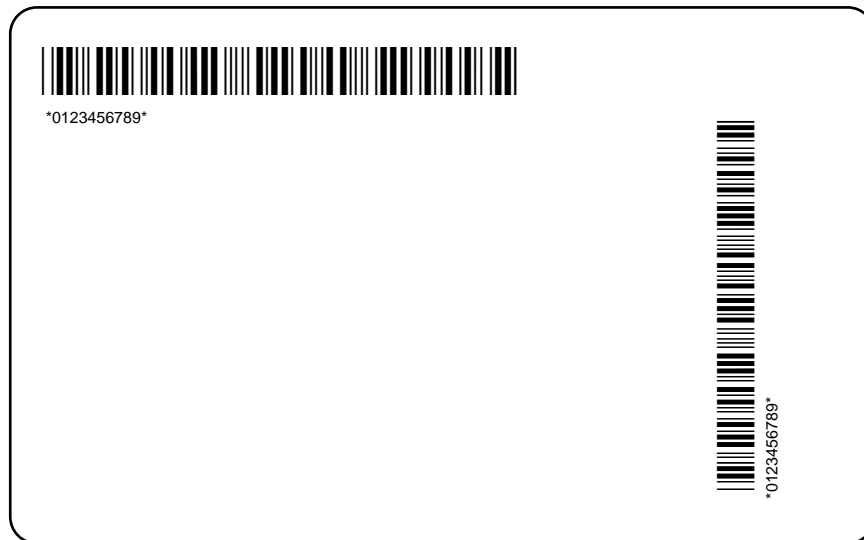

3240U.021

---

### ***Using a Different Platform Than a PC***

If you are operating your 3240 printer from a platform not discussed in this manual, it is important to keep several things in mind:

- The 3240 is an ASCII printer.
- You must configure the 3240 printer to match the settings of your platform to ensure proper communications.
- You must download data correctly structured for the commands. Refer to the *IPL Programming Reference Manual* for more information.
- Ensure that the cable you are using to communicate with the printer has the correct pin-outs. Use the cable schematics in Appendix B for reference.



# 3

## ***Maintaining the Printer***



*This chapter contains cleaning procedures and a schedule detailing how often to perform maintenance procedures. Even though the design of the 3240 printer enables it to withstand harsh environments, you must clean it on a regular basis to keep it running at its highest performance level. It is very important to perform the maintenance procedures if you expose the printer to dirt or debris. For information on maintenance procedures such as replacing media or ribbon, see Chapter 1, “Getting Started,” and Chapter 2, “Operating the Printer.”*

## ***Inspecting the Printer***

---

Inspect the printer and the rest of your data collection system equipment on a regular basis. Your inspection should include the following:

- Make sure you have properly grounded the printer.
- Inspect the work environment. Large electric motors, welders, and switching equipment can affect printer performance. See Appendix B, “Cabling and Communications,” for guidelines on appropriate environments.
- Keep the printer away from liquids.
- Check the data collection network regularly for loose wires or poorly installed connections. Be sure to replace corroded wires.

## ***Cleaning the Printer***

---

To clean the printer safely and effectively, use the following items:

- Isopropyl alcohol
- Cotton swabs
- Clean lint-free cloth
- Vacuum cleaner
- Soapy water/mild detergent

The following procedures explain how to access the printer parts and clean them without causing any harm to the printer or yourself.

## Maintenance Schedule

---

Clean your printer regularly to maintain the quality of your labels and extend the life of your printer. This table contains suggestions for cleaning the printer. Use the illustration to locate the parts you need to clean.

Printer Component	Maintenance Period
Printhead	Inspect after every roll of media. Clean after every roll (or 6,000 inches) of media or more often if necessary.
Printer Cover	Clean as necessary.
Drive Roller Thermal Transfer Ribbon (TTR) Assist Roller Self-Strip Roller Supply Roll Roller Tear Bar Media Path Edge Guide Upper Media Guide Lower Media Guide Label Gap Sensor Label Taken Sensor Pinch Roller	Clean after every five rolls of media. If you are using hi-tack adhesive, you must clean after every roll of media. If you are using tag stock or continuous media, you may want to clean after every five rolls of media or as necessary. Clean more often in environments that are harsh or dusty.

**Locating the Printer Parts You Need to Maintain**

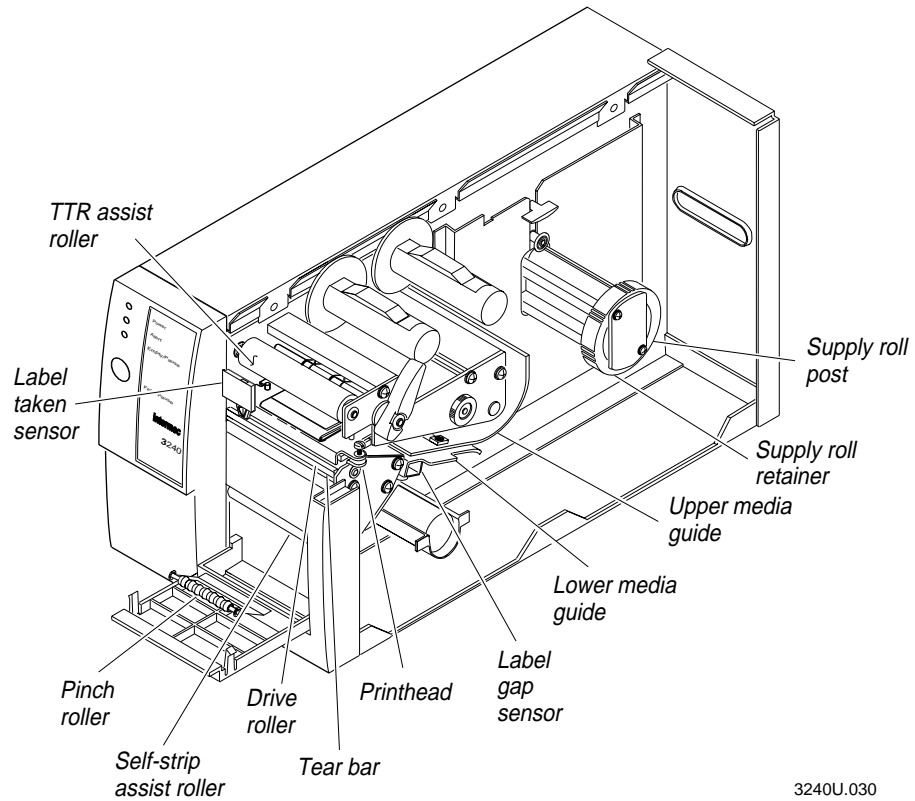

**Warning**

**Switch off the printer power and remove the power cord before cleaning any part of the printer.**

**Avertissement**

**Mettez l'imprimante hors tension et débranchez le câble d'alimentation avant de nettoyer une partie de l'imprimante.**

---

## ***Cleaning the Printhead***

In order for the printhead to provide good print quality, it must maintain close contact with the media. Therefore, cleaning media debris from the printhead is very important. You should clean the printhead after every roll (or 6,000 inches) of media or more often if necessary.



### **Caution**

***Do not use sharp objects such as knives or screwdrivers to scrape the printhead clean. Cleaning with sharp objects will damage the printhead. Clean with only a cotton swab, or a clean, lint-free cloth or tissue damp with isopropyl alcohol.***

### **Conseil**

***N'utilisez pas d'objets pointus tels que couteaux ou tournevis pour nettoyer la tête d'imprimante. Nettoyer avec des objets pointus endommagera la tête d'imprimante. Nettoyez-la seulement avec de la ouate ou avec un linge propre et libre de peluches, humecté avec de l'alcool d'isopropyl.***

### **To clean the printhead**

1. Turn the ON/OFF switch to the off position and remove the power cord.
2. Remove the media cover.
3. Disengage the printhead by rotating the head lift lever clockwise until the printhead releases. This action raises the printhead so that you can clean it.
4. Remove the media and ribbon if necessary.
5. Use a cotton swab moistened with alcohol to remove any dirt, adhesive, or debris from the print surface on the bottom of the printhead.
6. Wait 5 to 10 seconds for the print surface to dry. Replace the media and ribbon.
7. Engage the printhead by rotating the head lift lever counter clockwise until it locks in place.
8. If you are finished cleaning, replace the media cover.

---

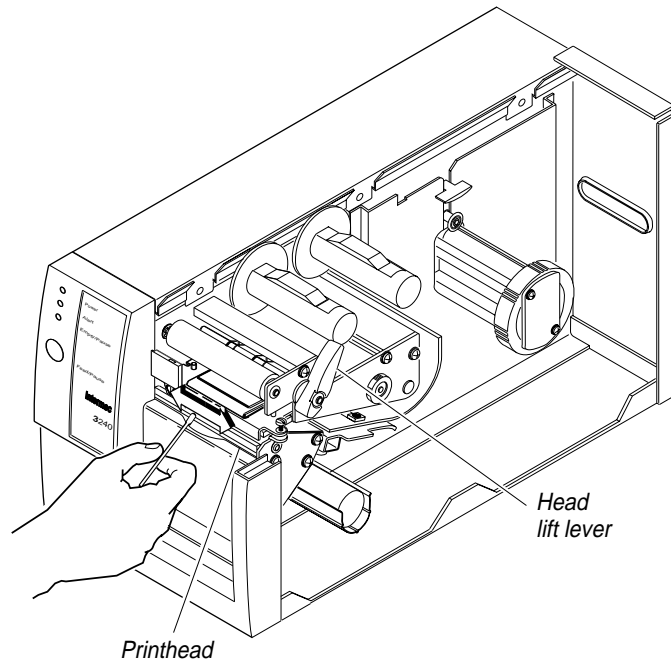
**Cleaning the Printhead**

3240U.031

---

**Cleaning the Printer Covers**

Clean the 3240 printer covers with a general purpose cleaner (soapy water/mild detergent). Do not use abrasive cleansers or solvents. Be sure to clean the transparent panel on the media cover so that the media supply inside the printer is visible when you close the cover.

---

## ***Cleaning the Rollers and the Tear Bar***

Cleaning the rollers and the tear bar preserves print quality by ensuring close contact between the media and the printhead.

### **To clean the rollers and tear bar**

1. Turn the ON/OFF switch to the off position and remove the power cord.
2. Remove the media cover.
3. Rotate the head lift lever clockwise to release the printhead.
4. Remove media and ribbon (if necessary).
5. Clean the rollers by using a cloth moistened with isopropyl alcohol. Move the cloth over the rollers in a side-to-side motion as shown. Make sure to rotate the rollers so you can clean all areas.

***Note:*** Rotate the TTR assist roller toward you to clean the entire drive roller surface.

6. Clean both sides of the tear bar with a cloth dampened with isopropyl alcohol. Remove all traces of dust, paper, and adhesive.
7. Replace the media and ribbon.
8. Engage the printhead by turning the head lift lever counterclockwise until the printhead locks.
9. If you are finished cleaning, replace the media cover.

**Cleaning the Rollers and Tear Bar**

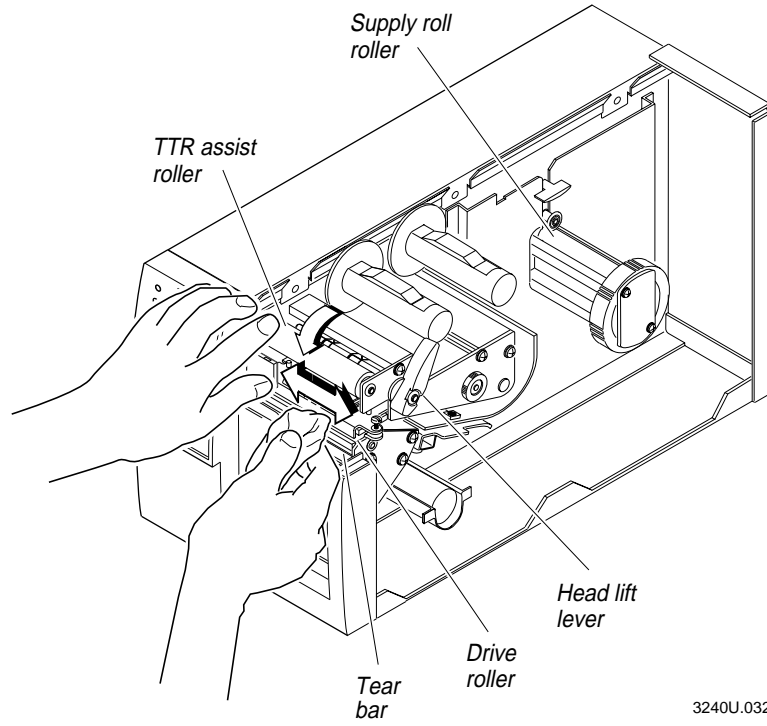

3240U.032

---

## ***Cleaning the Media Guides and Media Path***

You should clean the media guides and media path regularly to keep debris off the media surface and printhead where irregularities can spoil print quality or damage the printhead. Cleaning the guides also prevents the media from skewing or improperly tracking as it travels through the media path, which can result in smeared images and print off the side of the label. Always clean the media guides immediately after a label jam in the printer.

### **To clean the media guides and media path**

1. Turn the ON/OFF switch to the off position and remove the power cord.
2. Remove the media cover.
3. Remove the media and ribbon (if necessary).
4. Pull down on the lower media guide to open up the media path.
5. Clean the lower media guide by using a lint-free cloth moistened with isopropyl alcohol as shown in the following figure.

**Note:** *The lower media guide is spring loaded and you must hold it open to clean.*

6. Use the cloth moistened with isopropyl alcohol to clean the upper media guide. Be sure to remove all traces of debris.
7. Remove all traces of dust, paper, and adhesive from the media path with a soft bristle brush or vacuum.
8. Clean the flat surfaces of the media path (including the edge guide) with a lint-free cloth and isopropyl alcohol.
9. Release the lower media guide.
10. Replace the media cover.

**Cleaning the Media Path and Media Guides**

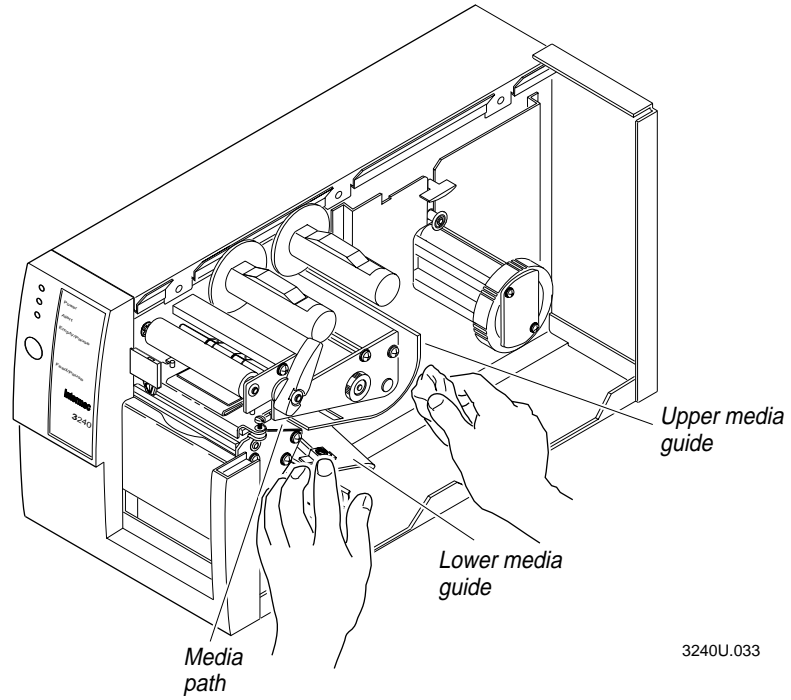

3240U.033

---

## ***Cleaning the Label Sensors***

There are two label sensors on the 3240 printer that require regular cleaning: the label taken sensor and the label gap sensor.

### **To clean the label sensors**

1. Turn the ON/OFF switch to the off position and remove the power cord.
2. Remove the media cover.
3. Disengage the printhead by rotating the head lift lever clockwise until the printhead releases.
4. Remove the media and ribbon (if necessary).
5. Clean the label taken sensor with a cotton swab moistened with isopropyl alcohol. Refer to the illustration.
6. Pull down on the lower media guide to expose the label gap sensor. Using a cleaning brush or vacuum, remove all debris and dust from the label gap sensor.

***Note:** You may want to slide the label gap sensor toward the outboard edge of the printer for better access. Make sure you return the label gap sensor to its original position when you finish cleaning.*

7. Clean the label gap sensor with a cotton swab and alcohol.
8. Replace the media and ribbon.
9. Engage the printhead by rotating the head lift lever counterclockwise until it locks in place.
10. Replace the media cover.

**Cleaning the Label Sensors**

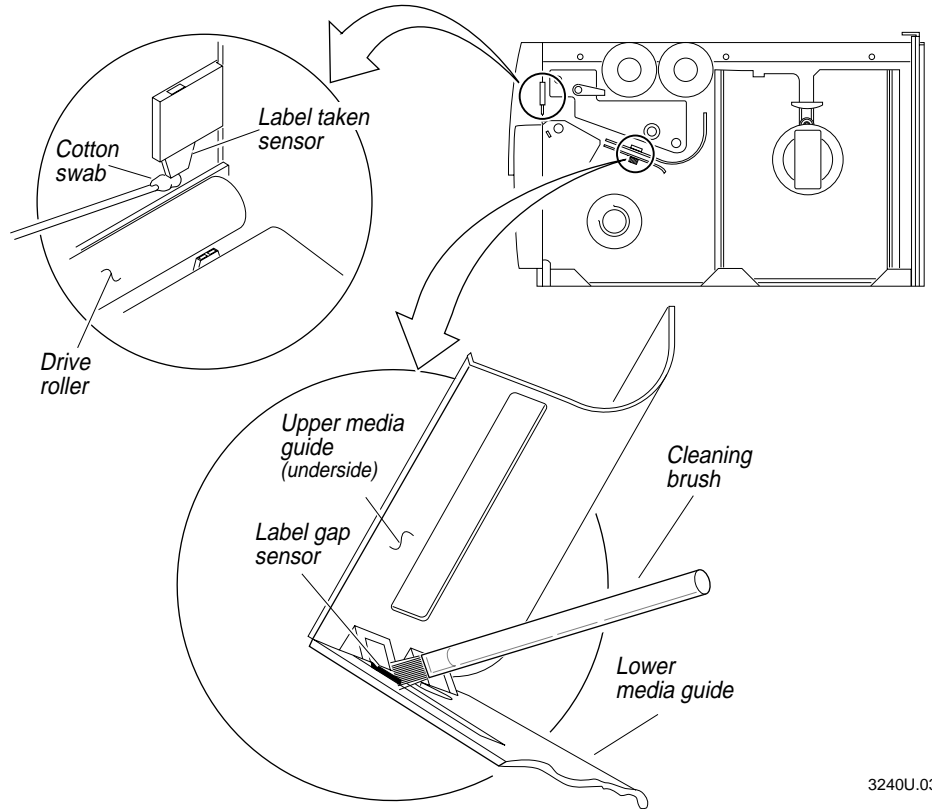

3240U.037



# 4

## ***Troubleshooting***



*This chapter provides some hints for troubleshooting error messages that the printer sends to the host and problems you may experience with the printer.*

## **Troubleshooting Checklist**

---

You may have printer operation, print quality, or printer communications problems at some time during the life of your printer. It is easy to fix most of the errors and consequently not delay operation of the printer for very long.

### **To troubleshoot your printer**

1. First try cleaning the printer components and checking all of the connections. See Chapter 3, "Maintaining the Printer," for details.
2. If cleaning the printer and checking the connections does not solve the problem, use the following tables to locate the symptom. Follow the solution in the table to fix your problem.

If you receive an error message, refer to the *IPL Programming Reference Manual* for a complete list of error messages and their solutions.

If the problem persists, contact your Intermec customer service representative. In the U.S. call 1-800-755-5505, and in Canada call 1-800-688-7043. If you are an international customer, contact your local Intermec representative.

## **Printer Operation Problems**

---

If your printer is not operating correctly, try locating the problem in the table below:

<b>Symptom</b>	<b>Possible Causes</b>	<b>Solution</b>
No power or loss of power.	You have damaged or disconnected the AC power cable.	Make sure you have plugged the power cable into both the printer and an outlet or power strip. Replace the cable if damaged.
	Printer circuit breaker tripped.	Turn the printer off and then back on again.
Labels stop feeding through the printer.	Printer is out of media.	Load new media. See Chapter 1, "Getting Started," or Chapter 2, "Operating the Printer."
	You have loaded the label stock incorrectly.	Check the media path. See Chapter 1, "Getting Started," or Chapter 2, "Operating the Printer."
	Media is sticking to the paper path.	Clean any extraneous material from the paper path and clean it thoroughly. See Chapter 3, "Maintaining the Printer."

---

**Printer Operation Problems (continued)**

	You have set the printer for continuous label stock.	Use PrintSet to check the configuration settings. If the settings are incorrect, use PrintSet to change the settings.
Printer slows down.	You have set the image bands or print speed incorrectly.	Use PrintSet to change the image bands or print speed settings.
	Printer has aborted and reset the print speed and image bands.	Use PrintSet to change the image bands or print speed settings.
The Alert LED flashes and printing stops.	Printhead has overheated.	Leave printer alone until it has time to cool down. It will resume printing on its own.
Media fault.	The printhead is up.	Make sure the printhead is down. The head lift lever should be straight up and down. Press the Feed/Pause button to resume printing.
	Sensor type set incorrectly.	Configure the printer for the correct sensor. Does this mean that I might have my printer configured for self-strip? What sensor? You can enable self-strip from PrintSet.
	You have incorrectly loaded the media.	Try reloading the media. For help, see "Loading a Roll of Media," in Chapter 1.
Labels stick to media access door or fail to strip.	The self-strip roller is dirty or the pinch roller is not contacting the strip roller.	Clean the self-strip roller. See Chapter 3, "Maintaining the Printer."
The stepper motor stalls while printing media that is less than 2.7 inches wide.	You did not properly adjust the bias adjust screw.	Adjust the bias adjust screw to the optimum printing position. See "Correcting Uneven Print Quality" in this chapter.
Test configuration labels do not print.	You have incorrectly loaded media.	Try reloading the media. For help, see "Loading a Roll of Media," in Chapter 1.
	You have configured the printer for self-strip media.	Set the printer to the default configuration using the DIP switches. For help, see "Plugging In the Printer," in Chapter 1.
	Media fault.	Remove media from under the label taken sensor.

## Print Quality Problems

If your labels are not being printed properly, check the following table to locate the symptom and correct the problem.

Symptom	Possible Causes	Solution
Blotches printing on labels.	Dirty printhead.	Clean the printhead. For help, see “Cleaning the Printhead,” in Chapter 3.
	Dirty media path or rollers.	Clean the media path. For help, see “Cleaning the Media Guides and Media Path,” in Chapter 3.
	Poor quality label or ribbon stock.	Use only Intermec label and ribbon stock to ensure superior print quality and product performance.
Printing is too light or too dark.	You have set the darkness adjust control incorrectly.	Adjust the knob to achieve the best print quality. See “Adjusting the Print Darkness” in this chapter.
	Poor quality label or ribbon stock.	Use only Intermec label and ribbon stock to ensure superior print quality and product performance.
	Dirty printhead.	Clean the printhead. For help, see “Cleaning the Printhead,” in Chapter 3.
	You set the sensitivity command incorrectly.	Change sensitivity setting to match the type of media you are using (for help, see “Setting the Media Sensitivity Number,” in Chapter 2). If you set the sensitivity setting correctly, try changing the dark adjust command.
Printing not aligned on label.	Print speed exceeds the capability of the media.	Lower your print speed or use Intermec media recommended for your print speed.
	Printer is misfeeding media.	Make sure you have correctly installed the media. For help, see “Loading a Roll of Media,” in Chapter 1.
Labels are not stopping at the right point for removal.	Label stock has moved in the media path.	Adjust the lateral printhead knob. See “Correcting the Lateral Position of the Label Image” later in this chapter.
	You have not set the label rest point command correctly.	Adjust the label rest point. For help, see your PrintSet online help or the <i>IPL Programming Reference Manual</i> .

---

**Print Quality Problems (continued)**

<b>Symptom</b>	<b>Possible Causes</b>	<b>Solution</b>
Labels not stopping at right point (continued).	You have set the printer for continuous label stock.	Set the printer to thermal transfer or direct thermal label stock. See "Loading a Roll of Media" in Chapter 1.
Print quality is poor.	Incorrect media sensitivity setting.	Change sensitivity setting to match the type of media you are using. If you set the sensitivity correctly, try changing the dark adjust command. For help, see your PrintSet online help, the <i>IPL Programming Reference Manual</i> , or "Optimizing and Maintaining Print Quality" in this chapter.
	Print speed exceeds the capability of the media.	Lower your print speed or use Intermec media recommended for your print speed.
	Printhead, platen roller, or label path is dirty.	Clean printhead, platen roller, and label path as described in Chapter 3, "Maintaining the Printer."
	Dirty media.	Keep media in a bag until you need it.
	The darkness of label print is too light or too dark.	Adjust the darkness adjust control. See "Adjusting the Print Darkness" in this chapter.
	Uneven print contrast (density).	Adjust the bias adjust screw. See "Correcting Uneven Print Quality" in this chapter.
	You are using incorrect label or ribbon stock to print labels.	Use only Intermec label and ribbon stock to ensure superior print quality and product performance.
	Ribbon wrinkling.	Check to make sure that you installed the ribbon correctly. For help, see "Loading Thermal Transfer Ribbon," in Chapter 2. Set the bias adjust screw. See "Correcting Uneven Print Quality" in this chapter.
	Ribbon installed upside down.	For help, see "Loading Thermal Transfer Ribbon" in Chapter 2.
	Direct thermal/thermal transfer switch set in the wrong position.	Set the switch for the type of media you are using. For help, see "Loading a Roll of Media," in Chapter 1.
	You have severely worn the printhead or platen roller.	Replace the platen roller or printhead.
	Media may be slipping against the platen roller, causing the printing to compress.	Switch to approved media or clean the printhead and platen roller as described in Chapter 3, "Maintaining the Printer."

***Print Quality Problems (continued)***

<b>Symptom</b>	<b>Possible Causes</b>	<b>Solution</b>
The printer skips labels randomly or sends an intermittent error.	The label gap sensor is not in the correct position.	Properly position the label gap sensor. For help, see “Accurately Detecting the Start of a Label” in this chapter.
	The label format extends beyond the label length.	Edit the format to ensure that the text fits on the label.
The printer is not waiting until you remove a label to print another.	You have not correctly positioned the label taken sensor over the media path.	Make sure that you position the label taken sensor over the media path. See “Adjusting the Printer for Self-Strip Printing” in this chapter.
Top of form shifts in self-strip mode after you lift the printhead.	The tension has changed on the liner.	Remove the accumulated liner from the rewinder hub. For help, see “Loading Media for Self-strip Printing” in Chapter 2.
Labels stop stripping while in self-strip mode.	There is too much liner accumulated on the rewinder hub.	Remove the accumulated liner from the rewinder hub. For help, see “Loading Media for Self-strip Printing” in Chapter 2.

***Communications Problems***

If your printer is not receiving downloaded data, try these solutions.

<b>Symptom</b>	<b>Possible Causes</b>	<b>Solution</b>
Printer does not communicate with the host.	You have not configured the serial port correctly.	Make sure the printer’s serial port settings match those of the host.
	Damaged or incorrect I/O cable.	Check the connections at both ends or replace the cable. See Appendix B for cable information.

## **Preventing Data Loss**

---

Several problems can cause data loss or communication problems on the 3240 printer. Data loss can result in printing errors or missing field data.

The 3240 printer is a serial ASCII device. It communicates with the host through an ASCII serial communications I/O port. Hardware handshaking involves the use of a hardware wire. Software handshaking involves a two-way datalink between the devices. The two devices communicate with each other without losing data through the use of handshaking. The printer sends both forms of handshaking simultaneously when the printer's input buffer is full. Any loss of data can cause printing errors or missing data.

Hardware handshaking uses pins 11 or 20 of the RS-232 interface to control data flow. When the printer is using Intermec Standard protocol, it holds pins 11 and 20 high when the printer is ready to receive data. The printer holds the pins low when the printer is in one of the following conditions:

- Buffer full
- Ribbon fault
- No label stock
- Label at strip pin

The 3240 printer uses XON/XOFF protocol for software handshaking. When the input buffer is full, the printer transmits an XOFF character. This character alerts the host to the fact that the printer buffer is full and cannot receive any more data. When the printer is ready to receive more data, it sends the XON character.

### **To check for communications problems**

1. Check the cabling from the printer to the host system.
2. Check the communications interfacing of the devices connected to the printer.
3. Check the printer for proper electrical operation of the I/O port.
4. Ensure that the host system is not overrunning the printer input buffers.
5. Ensure that the data string being sent to the printer contains the correct information.

## ***Optimizing and Maintaining Print Quality***

---

Intermec designed and configured the 3240 printer to provide the best possible print quality for both direct thermal and thermal transfer media. However, there are many factors that you need to take into account before you can achieve maximum print quality for your own application. The following sections address these factors:

- Selecting the correct media.
- Setting the print speed.
- Selecting the correct media sensitivity number.
- Selecting the correct bar code orientation.
- Adjusting the print darkness.
- Adjusting the printer for self-strip printing.
- Using Precision Print technology to print high registration labels.

---

### ***Selecting the Correct Media***

Media selection is one of the most important decisions you can make concerning print quality. The 3240 printer supports a wide selection of both direct thermal and thermal transfer media. To achieve optimum performance in your application, you must evaluate requirements such as print speed and environmental conditions.

It is important that you select the proper media when printing at higher speeds. Using good quality media reduces the occurrence of images that fade or bleed. If you want to print quality labels at higher print speeds, you must select media with low reaction or release imaging temperatures. Printing at lower speeds produces the highest quality labels. However, it is ultimately up to you and your Intermec Applications Analyst to decide the proper media for your application.

Please consult your Intermec Applications Analyst to ensure the selection of the proper media for your individual application. Refer to “Setting the Media Sensitivity Number,” in Chapter 2 for a complete list of available media.

---

## ***Setting the Print Speed***

The print speed you select affects the printed image. Therefore, it is important to select the proper media when printing at higher speeds. You can produce the highest quality labels at lower speeds. You can achieve optimal print quality for most direct thermal media at speeds below 3.0 ips.

To print labels as quickly as possible, you must adjust the print speed in conjunction with the number of image bands. The print speed and image band settings determine the rate at which the printer processes the images of your labels. This image processing rate in turn affects the speed of the entire printing process. See “Maximizing Throughput” in Chapter 5 for more information.

To achieve optimal print quality at speeds greater than 3.0 ips, you may need to fine-tune the printer (or select thermal transfer media). At higher speeds, it is important to properly set the sensitivity number and the dark adjust. If necessary, further adjustment of controls such as the bias adjust screw can improve print quality.

---

## ***Selecting the Correct Media Sensitivity Number***

Intermec prints a three-digit sensitivity number on each roll or box to specify a heating schedule optimized for print speed and print history. Each print element on the 3240 printer heats individually and various types of media require different temperatures. Therefore, each heating schedule is unique due to different media chemistries and manufacturing processes. Intermec developed these heating schedules to produce the highest possible print quality for bar codes.

Before you load media into the printer, check to see that the sensitivity number for the media matches the number set in the printer. This improves the print quality and sets the darkness to an appropriate level. The 3240 default setting for direct thermal media sensitivity is 420. For thermal transfer media, the default setting is 567. For information on setting the media sensitivity, see “Setting the Media Sensitivity Number” in Chapter 2.

---

## ***Selecting the Correct Bar Code Orientation***

You can alter the format to improve print quality and print speed. At high speeds, you can produce the best quality bar codes by using the drag orientation (printing parallel to paper motion). For more information on formats, please see the *IPL Programming Reference Manual*. See the Glossary for an explanation of drag and picket bar code orientations.

## Adjusting the Print Darkness

Use the darkness adjust control in combination with the Print Darkness adjustment in PrintSet to fine-tune the darkness of print on your labels. The fine adjustments compensate for variations in the media (“lot to lot”), the printhead, or the printer. Set the darkness adjust control after you enter the media sensitivity number.

### To adjust the print darkness

1. Locate the darkness adjust control on the back of the printer.
2. Use a small straight-slot screwdriver to adjust the print darkness.
  - To increase the print darkness, turn the darkness adjust control clockwise.
  - To decrease the print darkness, turn the control counterclockwise.

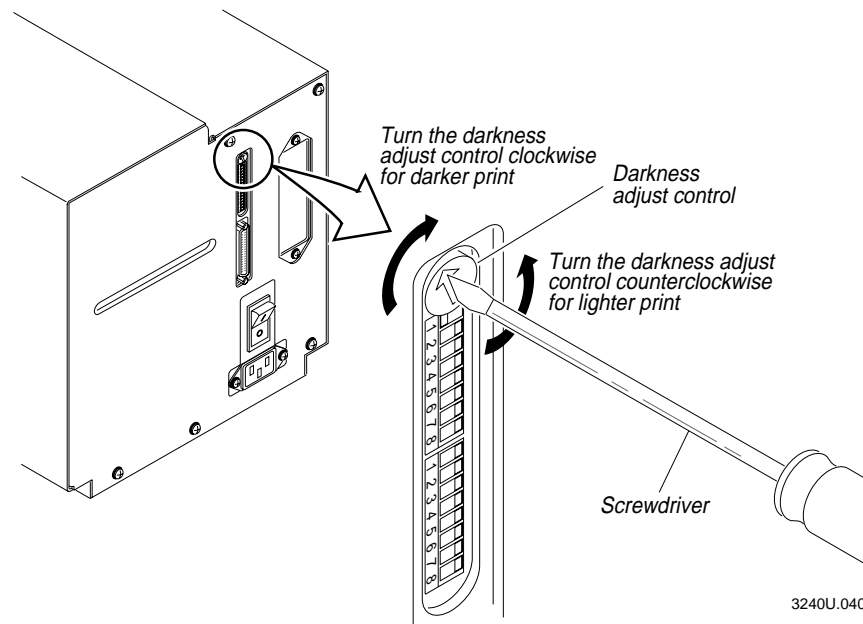

---

## ***Adjusting the Printer for Self-Strip Printing***

If your 3240 printer is continuing to print labels even when there is a label waiting for removal at the tear bar, you may need to adjust the label taken sensor. The label taken sensor detects whether there is a label present at the tear bar. The printer uses this sensor to determine when you remove a stripped label and when it can print the next label. You can only use this sensor with the self-strip option.

**Note:** *It is only necessary to adjust the label taken sensor when using very narrow labels (less than 0.5 inch).*

### **To position the label taken sensor**

1. Slide the label taken sensor up to 3/8 inch from the inboard edge of the media path.
2. Align the label taken sensor over the straight edge of the label at the tear bar.

For narrow label stock, you may want to position the label taken sensor in the middle of the label. The following illustration shows how to position the label taken sensor for narrow label stock.

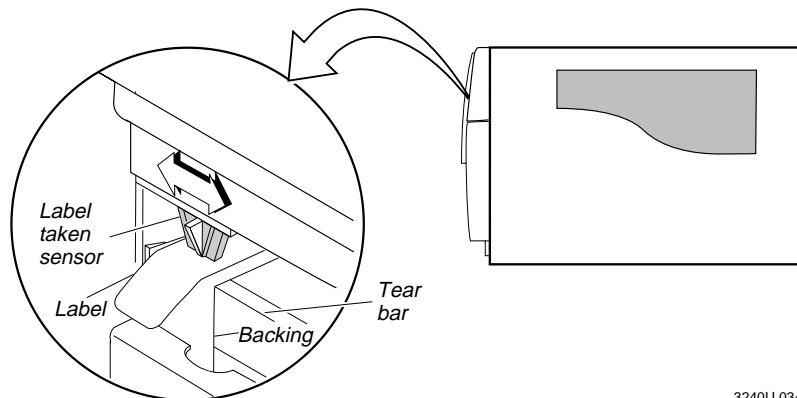

3240U.034

---

## ***Using Precision Print Technology to Print High Registration Labels***

The 3240 printer uses Precision Print technology to perform high registration printing. High registration printing means that the printer tracks the movement of media and automatically adjusts to ensure accurate horizontal (top of form) placement of an image on the label. Use the Precision Print technology and the adjustable features of the printer to ensure high registration printing by:

- correcting the lateral position of the label image.
- accurately detecting the start of a label.
- correcting uneven print quality.
- fine-tuning the top of form position.

### ***Correcting the Lateral Position of the Label Image***

If your label image is no longer printing in the middle of your label, you may need to adjust the lateral position of the printhead. Use the lateral printhead knob to compensate for lateral movement of media in the media path or variations in a roll of media. You can move the printhead 0.10 inch in either direction.

**Note:** Do not raise the printhead before attempting to adjust the lateral position of the printhead.

#### **To adjust the lateral printhead knob**

1. Remove the media cover.
2. Gradually turn the lateral printhead knob while printing and observe how the image is moving on the label.
  - Turn the knob clockwise to move the printhead toward the inboard edge of the media path.
  - Turn the knob counterclockwise to move the printhead toward the outer edge of the media path.
3. Adjust the lateral printhead knob until the image prints exactly where you want it to on the label.

In the first part of the following illustration, the label image starts out printing too close to the outside edge of the label. By turning the lateral printhead knob clockwise, the label image moves closer to the inside edge of the label. In the lower part of the illustration, the label image prints exactly where you want it to, in the center of the label.

4. Replace the media cover.

**Adjusting the Lateral Printhead Knob**

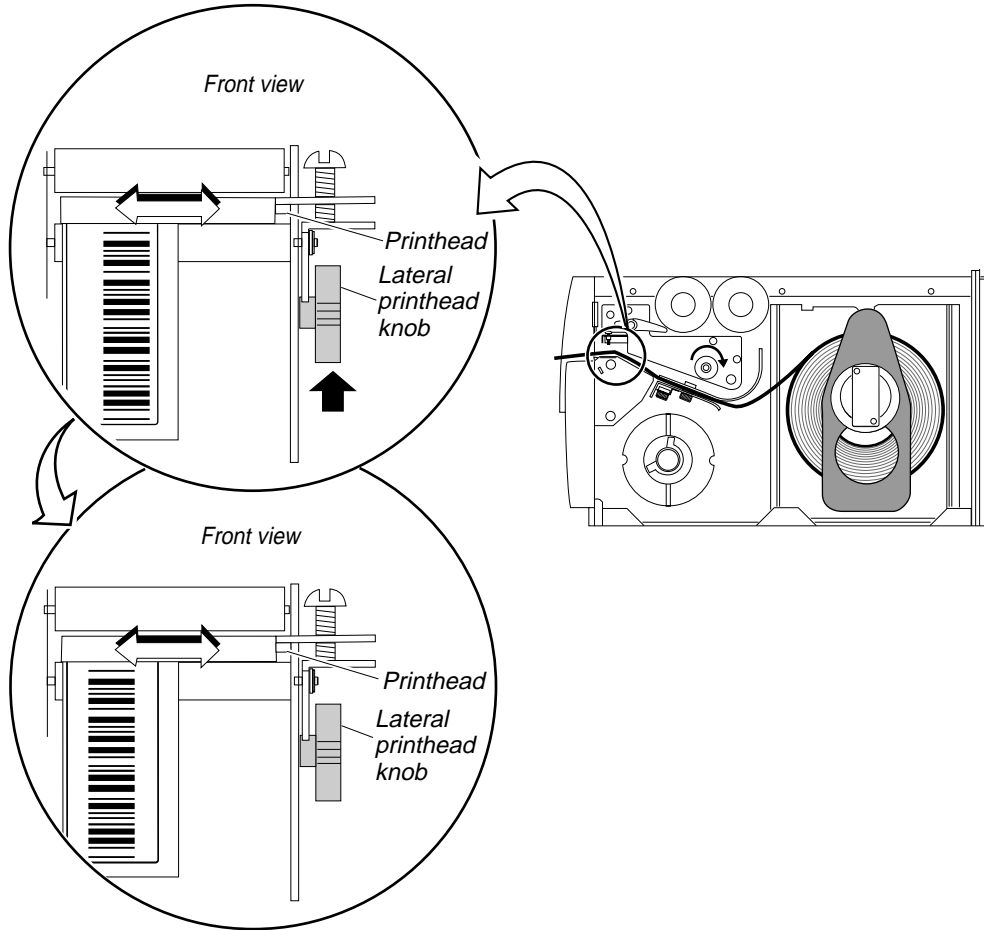

3240U.036

### ***Accurately Detecting the Start of a Label***

If you experience problems such as the printer skipping labels or the printer stopping and the yellow LED flashing, you may need to adjust the label gap sensor. You are most likely to experience any of these problems if you are using very narrow label stock and the label gap sensor is not in the correct position. You can adjust the label gap sensor from 0 to 1.0 inch from the inner edge of the printer.

*Note: Intermec sets the label gap sensor to 0.5 inch from the inner edge of the printer at the factory. You should be able to leave it in this position for most labels wider than 1.0 inch.*

#### **To adjust the label gap sensor**

1. Remove the media cover.
2. Turn the label gap sensor knob counterclockwise and slide the sensor all of the way to the inner edge of the lower media guide.
3. Tear off one of the labels from your roll of media and line it up with the 0 (zero) on the lower media guide.
4. Slide the label gap sensor knob to the position where the label gap sensor indicator is in the middle of the label. The label gap sensor indicator is the part of the label gap sensor knob that is visible from the top of the lower media guide.

Here are some guidelines for you to follow:

- If your labels are less than 1.0 inch wide, position the label gap sensor in the middle of the label.
- If your labels are greater than 1.0 inch wide, position the label gap sensor over the straight edge of the label.
- If your labels are round, position the label gap sensor over the middle of the radius edge.

---

**Adjusting the Label Gap Sensor**

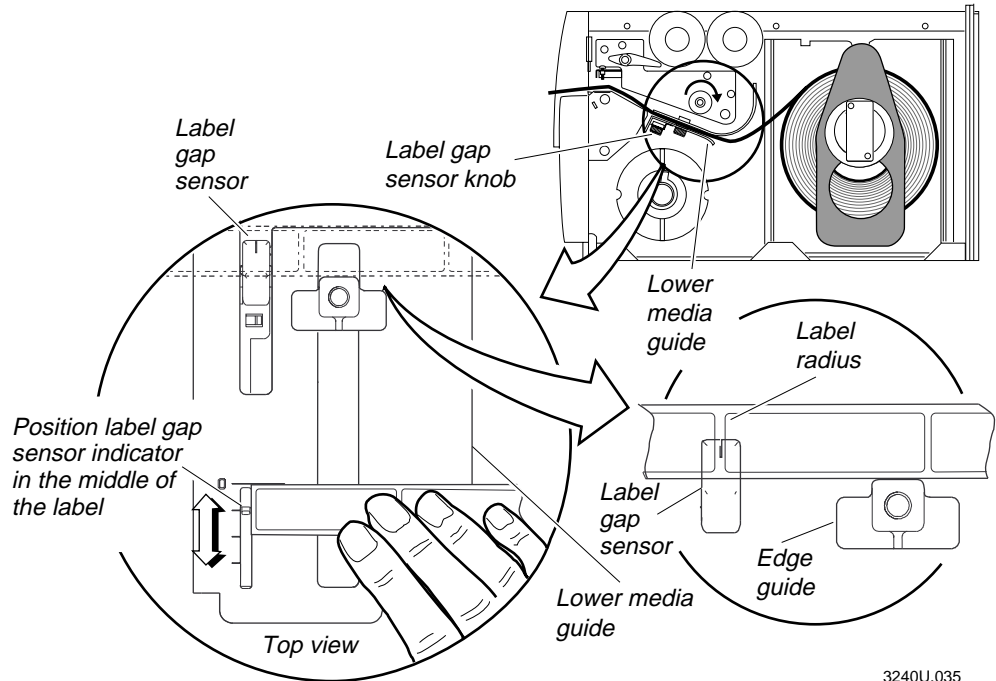

5. Turn the label gap sensor knob clockwise to secure it in the new position.
6. Try printing a label to see if the printer is detecting the start of the label (top of form).
7. If the printer is still not detecting the top of form, slide the label gap sensor a little further toward the outer edge of the lower media guide.
8. Replace the media cover.

### ***Correcting Uneven Print Quality***

You may experience problems in print quality (ribbon wrinkling or light print on one side of your label) if the printhead is not making even contact with the label stock. This condition can happen with any size label stock, but is most common when using narrow label stock (1 inch or less). You need a straight-slot screwdriver to turn the bias adjust screw.

To achieve the best print quality, adjust the bias adjust screw each time you use media of a different width.

**Note:** *You must properly adjust the bias adjust screw to prevent premature printhead failure and excessive platen wear.*

#### **To adjust the bias adjust screw**

1. Remove the media cover and locate the bias adjust screw.

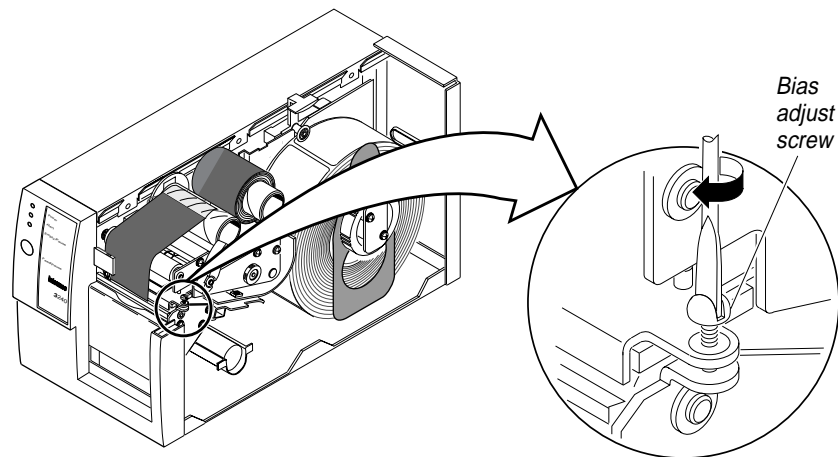

3240G.041

2. To compensate for uneven print quality, turn the bias adjust screw as shown.

Adjusting the bias adjust causes the printhead to rest evenly on the drive roller and results in even print quality.

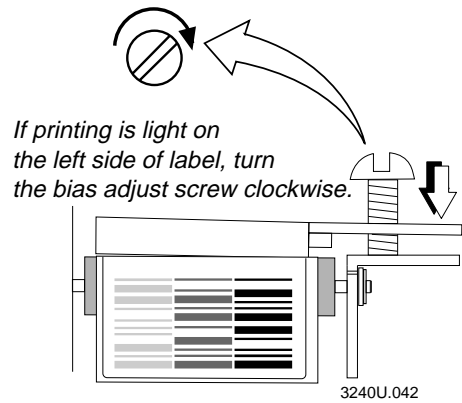
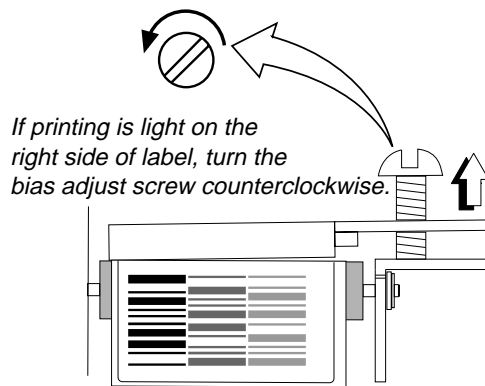

3. Replace the media cover.

### ***Fine-Tuning the Top of Form Position***

If your label format prints too close to the front or back edge of the label, you can fine-tune the position with the top of form (TOF) switch. The TOF switch controls the position of the format forward or backward along the length of the label.

This feature is especially important if you are printing small labels in self-strip mode because you can easily adjust for slight shifts in the label format without stopping the printer or sending down software commands.

Only use the TOF switch to fine-tune your label format position. This is important because the printer returns to your initial TOP setting when you:

- cycle printer power.
- lift the printhead.

Use the TOF switch to fine-tune the format position after you design the label. Use PrintSet or the IPL top of form command to control the initial TOF setting. For help on using the top of form command, see the PrintSet help or the *IPL Programming Reference Manual*.

The TOF switch is a small rocker switch located on the lower outboard plate of the printer.

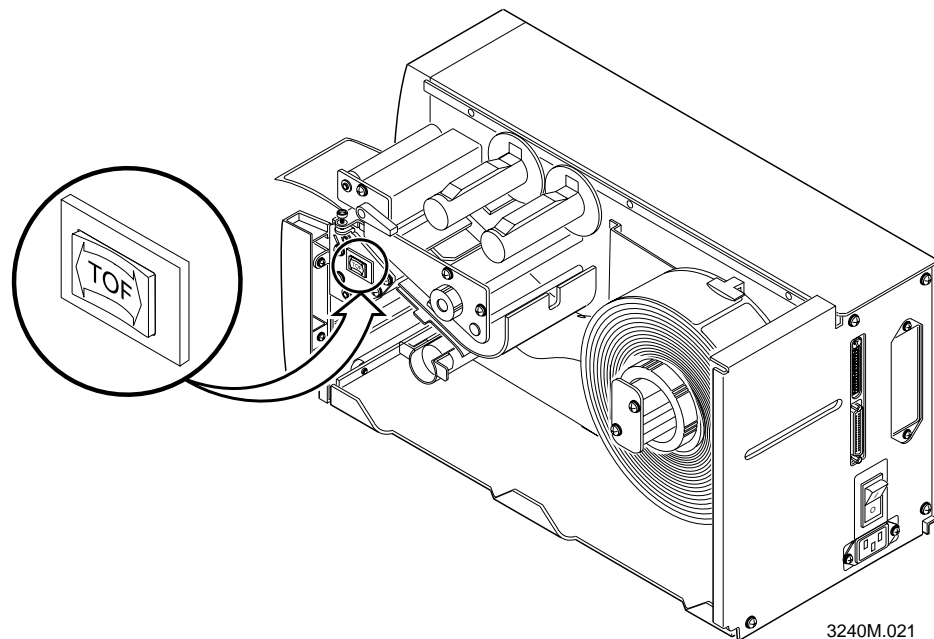

**To move a label format backward with the TOF switch**

**Note:** You will see the new format position on the second label you print after pressing the TOF switch.

You notice that your format is printing toward the from part of the label.

← Label direction from printer

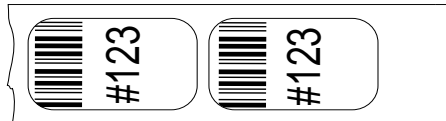

3240M.023

1. Remove the media cover.

**Note:** Do not raise the printhead while adjusting the TOF position.

2. Press on the back part of the TOF switch. Each time you press the TOF switch, you move the label format backward .005 inch (1.27 mm).

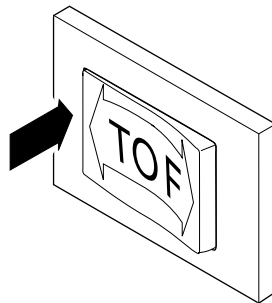

3240A.003

3. Press the TOF switch repeatedly until your format moves backward to the correct position on the label.

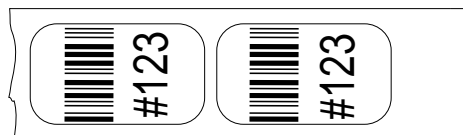

3240M.025

**To move a label format forward with the TOF switch**

You notice that your format is printing toward the back part of the label.

← Label direction from printer

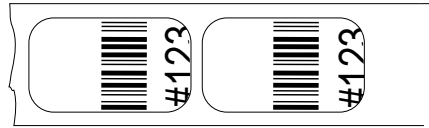

3240M.026

1. Remove the media cover.

**Note:** Do not raise the printhead while adjusting the TOF Position.

2. Press on the front part of the TOF switch. Each time you press the TOF switch, you move the label format forward .005 inch (.127 mm).

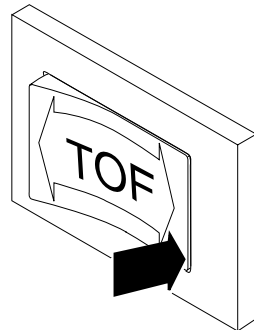

3240M.024

3. Press the TOF switch repeatedly until your format moves forward to the correct position on the label:

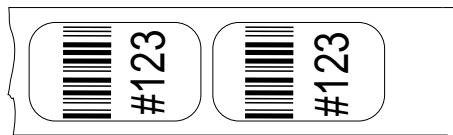

3240M.025



# 5

## ***Performing Advanced Procedures***



*This chapter explains how to:*

- *Use the printer memory more efficiently.*
- *Maximize throughput.*
- *Use Test and Service mode.*
- *Change configuration commands in Test and Service mode.*

## ***Using the Printer Memory Efficiently***

---

To receive the best performance from your 3240 printer, you must understand how to use the printer RAM. The following sections help you determine the most efficient way to use your printer memory. It is important to remember that using a lot of available memory for storage reduces the amount of memory you can use for imaging. The end result is a decrease in printer performance.

---

### ***How Is the 3240 RAM Used?***

There is enough RAM in the printer to store several different label formats and still retain enough memory to store downloaded fonts, graphics, and data. Be careful of how you use your printer memory.

The 3240 printer uses static RAM for storing tables, pages, formats, fonts, and user-defined characters (UDCs). For a printer with 128K of static RAM installed, the default amount allocated for storage RAM is 60K. You can use any RAM not allocated for storage for imaging. Use PrintSet to adjust the amount of RAM allocated for storage purposes from 10K to 120K. If you require additional RAM, a 512K memory expansion option is available.

The printer supports the following parameters independent of the amount of static RAM installed or allocated by the printer:

- Maximum number of formats: 20 (You can edit formats 1 to 99. You cannot edit default format 0.)
- Fields per format: 200
- Maximum data buffer size for a field: 3000
- Maximum number of UDCs: 100
- Maximum number of user-defined fonts: 16

---

## ***Making the Most of Your RAM***

There are limits to the number of formats, fonts, graphics, or pages that you can store in the printer. You can define up to 16 fonts, but there may not be enough room depending on the amount of memory being used for other purposes. The more formats, graphics, and fonts you store, the less memory is available.

When you run into a memory usage problem, use PrintSet to see how much memory remains available. The printer uploads information on the amount of storage RAM allocated and the amount of allocated RAM that you are not using. The printer uses a comma to separate the two numbers. For example, the printer may send back the following: 120,10 (indicating that you have 120K allocated for storage and that you are not using 10K). If you find that it is necessary to increase your available memory, you can do one of the following:

- Adjust the amount of RAM allocated for storage purposes using the PrintSet software.

A printer with 128K of static RAM installed can adjust the amount of RAM allocated for storage from 10K to 120K. For printers with expanded RAM (512K) installed, you can adjust the amount of storage RAM from 10K to 504K. If you set the amount of RAM to an amount too small to hold the existing formats, pages, fonts, and UDCs, the printer erases them.
- Increase the amount of available memory by using the Memory Reset portion of the Test and Service menu. See “Using Memory Reset” later in this chapter for more information.
- Delete any unneeded user-defined fonts, graphics, pages, or formats. For help, see the PrintSet software or the *IPL Programming Reference Manual*.
- Purchase additional memory. Please contact your Intermec representative for information on purchasing additional memory for the 3240 printer.

## ***Maximizing Throughput***

---

To print labels as quickly as possible, you must adjust the print speed in conjunction with the number of image bands (one image band equals 1 inch of label). The print speed and image band settings determine the rate at which the printer processes the images of your labels. This rate in turn affects the throughput of the entire printing process.

The 3240 printer begins imaging the label when it receives the command to select a format. Since the 3240 printer starts imaging the label so early, the chance that the imaging process will be unable to keep up with the print speed decreases and throughput improves. However, if the number of image bands is too low, the imaging process is unable to keep up with the print speed. In this case, the printer stops printing and starts again at the lowest print speed with the maximum number of image bands. If you have set the image band command too high, the printer spends more time than necessary imaging and slows down label production.

---

### ***What Is an Image Band?***

Image bands are a section of memory where the printer draws a picture of a label format. We call this process imaging. Once the printer images the picture, the printer loads the picture from the image bands to the printhead for printing. Each image band is equal to 1 inch of length of the label format. The number of image bands you use may be less than the length of the label you are printing. The number of image bands (in inches) does not have to equal the length of the label since the printer recycles the image bands. Once the printer prints the contents of an image band, it can reuse the band to image the next section of the label.

Keep in mind that the more complex the label, the longer it will take to image each section, thus requiring a slower print speed. To use a higher print speed, use more image bands to allow more of the imaging process to complete before printing begins.

---

## ***How the Image Bands Command Works***

The image bands command controls the amount of memory allotted to the imaging process. When you increase the image band adjustment to a higher number, you add more buffers to the imaging memory. By doing this, the printer images more of the label format before printing begins.

The minimum number of required image bands is dependent upon the print speed and the complexity of the label. Labels that contain numerous fields with different rotations, graphics, or combinations of any number of these formatting options may require a higher number of image bands.

To set the number of image bands, use PrintSet or the IPL command. For help, see the PrintSet online help or the *IPL Programming Reference Manual*.

---

## ***Optimizing Print Speed and Image Band Setting***

The maximum number of image bands available for use is 5 bands with 128K of static RAM or 7 bands with expanded RAM. The minimum number of image bands available is 2.

### **To optimize the number of image bands for your print speed**

1. Set the image band setting to the lowest number (2).
2. Print a label at the desired speed.

If the label prints, the image band setting is optimal. You do not need to perform any more adjustments.

If the number of image bands is too low, the printer aborts the label before it completes printing and attempts to reprint the label at the slowest speed (2 ips) with the highest number of image bands (5). You need to continue with Step 3.

3. Return to the original print speed and increase the original number of image bands one at a time.

Continue to increase the number of image bands until the printer prints a label correctly.

If the printer still aborts and reprints at the highest image band setting, you may be trying to optimize at a print speed that is too high for your label format. Try optimizing the number of image bands at a lower print speed or add expansion RAM.

To print very complex labels at high speeds, you must allocate enough image bands to completely image the label before printing. Allocate one band for each inch of label length. By doing this, you can print at any speed. However, there may be a considerable delay between labels.

---

## **Reimaging Modified Fields**

You can now choose to reimage only the fields in a label format that you modify instead of reimaging the entire label format. If you are updating data in only a few simple fields, it may be faster to use the modified field reimaging command. However, you need to take into account the type of fields you will be reimaging. If you choose to reimage a field that takes longer to erase and reimage than it takes an entire label format to erase and reimage, you will not be increasing throughput. Erasing a field requires reimaging it with zeros, and erasing a label requires only clearing the RAM. When you use it correctly, this command parameter can greatly increase the throughput of your printer.

### **To use the modified field reimaging command**

1. Make sure that you select enough image bands to allow the printer to retain the entire label image.

One image band is equal to 1 inch of label length and 50K of RAM.

2. Select the fields to reimage by using PrintSet. For more information on how to reimage modified fields, see the *IPL Programming Reference Manual*.

---

## **Optimizing Image Bands for Batch Printing**

If you frequently print batches of identical labels (using the <US> command) or print a quantity of identical labels, you may want to optimize the number of image bands for batch printing. This optimization is especially helpful if you experience delays between the printing of each label.

To optimize the number of image bands for batch printing, you must select enough image memory to allow the printer to retain the entire label image. To optimize batch printing, select the number of image bands (1 band = 1 inch) to equal the label size. Therefore, if the printed image stops at a distance of 2 inches from the beginning of the label, you must select two image bands to prevent reimaging if the label is 3 inches long.

## **Using Test and Service Mode**

---

Use Test and Service mode on the 3240 printer to print test labels and provide printer hardware diagnostic information to the host.

*Note: For all Test and Service tests, pressing the Feed/Pause button pauses the current test. Holding the Feed/Pause button aborts the current test and starts a new test.*

### **To enter Test and Service mode**

1. Turn the ON/OFF switch to the off position.
2. Press and hold the Feed/Pause button while turning the printer power on.  
The printer prints out a hardware configuration label and then enters Data Line Print mode.
3. Set the DIP switches to the test or service function you wish to perform. See the following table for a list of the DIP switch settings.
4. Hold the Feed/Pause button down for 1 second. The test begins immediately.
5. If you wish to perform another function, change the DIP switch settings and press the Feed/Pause button.  
The function the printer is currently executing terminates, and the printer performs the new function.
6. To exit Test and Service mode, turn the printer power off and then on again.

*Note: Be sure to return all DIP switches to their original settings after completing the configuration tests and before powering the printer back on.*

The printer remains in Test and Service mode until you turn the power off again and reset the DIP switches. The printer executes all functions as soon as you select them.

Use the information in the following table to set the DIP switches for the appropriate Test and Service mode function you want to perform.

**Test and Service Mode DIP Switch Settings**

	Top Bank								Bottom Bank														
	OFF								ON														
TESTS	1	2	3	4	5	6	7	8	1	2	3	4	5	6	7	8							
<b>Test Prints</b>	O O O																						
Configurations	O O O																						
Hardware*	O O O																						
Software	1 O																						
Test Labels	1 O O																						
Print Quality	O O																						
Pitch	1 O																						
Page	O 1 O O O																						
Single Page									N	N	N	N	N				Q						
All Pages									1	1	1	1	1				Q						
Format	1 1 O O O																						
Single Format									N	N	N	N	N				Q						
All Formats									1	1	1	1	1				Q						
UDC	O O 1 O O																						
Single UDC									N	N	N	N	N	N	N	Q							
All UDCs									1	1	1	1	1	1	1	Q							
Font	1 O 1 O O																						
Single Font									N	N	N	N	N				Q						
All Fonts									1	1	1	1	1				Q						
<b>Data Line Print</b>	*1 O O O O O O O																						
<b>Cloning</b>	O 1 O																						
Receiver	O O O O O																						
Sender	1 O O O O																						
<b>Selective Transfer</b>	1 1 O																						
Receiver	O O O																						
Send Pages	1 O O S																						
Single Page									1	S							S	S	S	D	D	D	D
All Pages									1	S							1	1	1	1	1	1	1
Send Format	O 1 O S																						
Single Format									1	S							S	S	S	D	D	D	D
All Formats									1	S							1	1	1	1	1	1	1
Send UDC	1 1 O S																						
Single UDC									1	S							S	S	S	S	S	S	S
All UDCs									1	S							1	1	1	1	1	1	1
Send Font	O O 1 S																						
Single Font									1	S							S	S	S	D	D	D	D
All Fonts									1	S							1	1	1	1	1	1	1
Send Configuration	1 O 1																						
Send Tables	O 1 1																						
Send All	1 1 1																						
<b>Memory Reset</b>	O O 1																						
Page/Format	O O O																						
UDC/Font	1 O O																						
Configuration	O 1 O																						
Tables	1 1 O																						
All	1 1 1																						

Q: OFF = Batch of 1. ON = Batch of 100.  
 N: Page/Format/UDC/Font number. Least significant bit is switch 8.  
 S: Source Page/Format/UDC/Font number. Least significant bit.  
 D: Destination Page/Format/UDC/Font number. Least significant bit.  
 \* Default settings are noted with an asterisk.

---

## ***Printing Test Labels***

The 3240 printer can print a variety of test print labels that provide you with information about the printer's configuration and about the quality of the printing.

### **To print out a test label**

1. Turn the ON/OFF switch to the off position.
2. Press and hold the Feed/Pause button while turning on the printer.  
The printer prints out a hardware configuration label and then enters Data Line Print mode.
3. Set the DIP switches to print out the test label of your choice: software, print quality, or pitch. Refer to the Test and Service DIP Switch Settings table for the correct settings.
4. Hold the Feed/Pause button down for 1 second.  
The printer begins printing out the test label immediately.
5. Exit Test and Service mode by turning the printer power off and then on.

---

## ***Using Data Line Print***

Use Data Line Print to troubleshoot communications between the printer and the host. You can also use it to test the operation of the printer. When the printer is in Data Line Print mode, it prints out all downloaded data with the hexadecimal equivalent printed directly underneath it. Holding the Feed/Pause button down momentarily suspends the test. Pressing the Feed/Pause button longer causes the printer to transmit the firmware program and version number to the host.

### **To enter Data Line Print mode**

1. Turn the ON/OFF switch to the off position.
2. Press down and hold the Feed/Pause button while turning on the printer.  
The hardware configuration test label prints out. You are now in Data Line Print mode.

---

## **Performing Selective Transfer**

If you want to copy select formats, pages, fonts, or graphics to another printer, use the Selective Transfer command. Use this command to set up different printers to print the same label formats.

Using the Selective Transfer command, you can download the following label design attributes from one 3240 printer to another:

- Any specified page or all pages
- Any specified format or all formats
- Any specified font or all fonts
- Any specified user-defined character (UDC) or all UDCs

When you set the printer DIP switches to the setting for Selective Transfer, you set the printer serial port to 19,200 baud, even parity, 1 stop bit, and 8 data bits. If you are transferring pages, formats, or fonts, the destination and source numbers can be different. If you are transferring UDCs, the destination and source number must be the same.

### **To perform Selective Transfer**

1. Turn the ON/OFF switch to the off position.
2. Press down and hold the Feed/Pause button while turning on the printer. The hardware configuration test label prints out.
3. Connect the serial ports of the sending and receiving ports together with an RS-232 null modem cable. See Appendix B, "Cabling and Communications," for cabling information.
4. Set the DIP switches on the sending printer and receiving printer for selective transfer as shown in the table of Test and Service Mode DIP Switch Settings on page 5-9.
5. Select the type of data that you wish to transfer (such as pages, formats, fonts, or UDCs) by setting the corresponding DIP switches shown in the table on page 5-9.
6. Press the Feed/Pause button on the receiving printer and then on the sending printer to initiate selective transfer.
7. Exit Test and Service mode by turning the printer power off and then on and returning all DIP switches to their original settings.

## ***Using Memory Reset***

Use memory reset if you want to return the 3240 printer to its default configuration or if you need to increase the amount of memory available in your printer. You can also use memory reset to clear pages and formats, user-defined characters and fonts, configurations, tables, or all of these parameters.

### **To use memory reset**

1. Turn the printer ON/OFF switch to the off position.
2. Press and hold the Feed/Pause button while turning on the printer. The 3240 prints a hardware configuration label and enters Data Line Print mode.
3. Set the DIP switches to reset a portion or all of the memory by using the Test and Service Mode DIP Switch Settings table located on page 5-9.
4. Hold the Feed/Pause button down for 1 second. The printer resets a portion or all of its memory.
5. To exit Test and Service mode, turn the printer power off and then on.

**Note:** *You can also use the Test and Service command (D) to reset all printer RAM.*

## Changing Configuration Commands in Test and Service Mode

Test and Service mode also provides you with an alternative way to change configuration commands besides sending configuration commands down from the host. You can change the following configuration commands by setting the Test and Service mode DIP switches:

- Label rest point
- Emulation mode
- X forms adjust
- Y forms adjust

The following table provides you with the Test and Service mode DIP switch settings for changing the configuration commands.

### Configuration DIP Switch Settings

	Top Bank								Bottom Bank							
	OFF								ON							
	1	2	3	4	5	6	7	8	1	2	3	4	5	6	7	8
<b>Label Rest Point</b>	O	1	1						N	N	N	N	N	N	N	N
Adjust Forward				O					N	N	N	N	N	N	N	N
Adjust Backward				1					N	N	N	N	N	N	N	N
<b>86XX Emulation</b>	1	O	1													
5.0 mil Advanced mode				O	O											
2.5 mil Advanced mode				O	1											
10 mil 86XX mode				1	O											
15 mil 86XX mode				1	1											
<b>X Forms Adjust</b>	1	1	1	1					N	N	N	N	N	N	N	N
Adjust Forward					O				N	N	N	N	N	N	N	N
Adjust Backward					1				N	N	N	N	N	N	N	N
<b>Y Forms Adjust</b>	1	1	1	O					N	N	N	N	N	N	N	N

N: Number. Least significant bit first.

3240U.043

## Setting the Number of Dot Increments

You can move the label rest point and X forms adjust configuration commands forward or backward by setting the printer DIP switches. Use the top bank of DIP switches to determine whether the movement is forward or backward. Use the bottom bank of DIP switches to set the number of dot increments for label rest point, X forms adjust, and Y forms adjust. If the printer is in 5 mil Advanced mode, it moves 0.005 inches per dot. If the printer is in 2.5 mil Advanced mode, it moves 0.0025 inches per dot.

**Note:** The table below only shows the settings for the bottom bank of switches. See the Configuration DIP Switch Settings table for the top bank DIP switch settings.

### Dot Increments DIP Switch Settings

Bottom Bank

0 = OFF  
1 = ON

OFF



ON

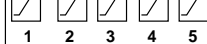

1 2 3 4 5

# of Dot Increments	1	2	3	4	5
1	1	0	0	0	0
2	0	1	0	0	0
3	1	1	0	0	0
4	0	0	1	0	0
5	1	0	1	0	0
6	0	1	1	0	0
7	1	1	1	0	0
8	0	0	0	1	0
9	1	0	0	1	0
10	0	1	0	1	0
11	1	1	0	1	0
12	0	0	1	1	0
13	1	0	1	1	0
14	0	1	1	1	0
15	1	1	1	1	0
16	0	0	0	0	1
17	1	0	0	0	1
18	0	1	0	0	1
19	1	1	0	0	1
20	0	0	1	0	1
21	1	0	1	0	1
22	0	1	1	0	1
23	1	1	1	0	1
24	0	0	0	1	1
25	1	0	0	1	1
26	0	1	0	1	1
27	1	1	0	1	1
28	0	0	1	1	1
29	1	0	1	1	1
30	0	1	1	1	1

3240U.062

**To set the number of dot increments**

1. In the top bank, turn the appropriate switches on or off for forward or backward movement. See the Configuration DIP Switch Settings table on page 5-13 for the appropriate DIP switch settings.
2. Go to the Dot Increments DIP Switch Settings table on page 5-14 and scan down the # of Dot Increments column until you reach the number of dot increments you want to adjust the command forward or backward.
3. In the bottom bank turn on the switches that have a 1 in their column. Turn off all other switches.
4. Press the Feed/Pause button and the printer prints out the software configuration label and stops at the new location.

For example, you print a label and discover that it does not extend far enough from the tear bar. You need to move the label rest point forward 10 dot increments (0.025 inch) so that the printer feeds more label out when it finishes printing. Find 10 in the # of Dot Increments column. It shows a 1 in the columns of DIP switches 2 and 4, and a 0 in the columns of 1, 3, and 5. The 1 tells you to turn the switch on. The 0 tells you to turn the switch off. Turn on switches 2 and 4. Turn off all other switches.

---

***Adjusting the Label Rest Point***

The Label Rest Point configuration command adjusts the point at which the printer presents each label for removal. Use this command in conjunction with self-strip applications. The label rest point adjust range is from -30 dot increments (furthest back) to +30 dot increments (furthest forward). Use a negative number if you want the printer to retract the label a number of dot increments after it prints the label. Use a positive number if you want the printer to feed the label a number of dot increments after it prints the label.

There are three ways to adjust the label rest point.:

- You can use the Test and Service DIP switch bank. Follow the procedure below to use the DIP switch settings to adjust the label rest point.
- You can set it by using the PrintSet application software. See the Paper Handling portion of PrintSet for more information.
- You can use the IPL command. See the *IPL Programming Reference Manual* for more information.

**To adjust the label rest point**

1. Turn the printer ON/OFF switch to the off position.
2. Press and hold the Feed/Pause button while turning on the printer.

The printer prints out a hardware configuration label and then enters Data Line Print mode.

3. In the top bank of the Test and Service mode DIP switches, turn off switch 1 and turn on switches 2 and 3.

To adjust the label rest point forward (feed more label), turn off DIP switch 4.

To adjust the label rest point backward (retract label), turn on DIP switch 4.

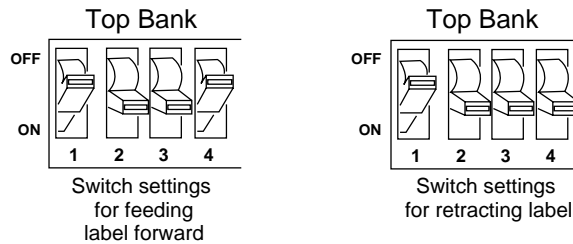

3240U.063

4. In the bottom bank of the Test and Service mode DIP switches, turn on or off the appropriate DIP switches. See the Dot Increments DIP Switch Settings table on page 5-14.
5. Press the Feed/Pause button.  
The printer prints out the software configuration label and stops at the new location.
6. Verify that the Label Rest Point number on the software configuration label matches the number you set in Step 4.
7. Try printing again to see if you need to readjust the DIP switches in the bottom bank.
8. If you need to readjust the DIP switches in the bottom bank, repeat Steps 4 through 6. If not, exit Test and Service mode by turning the printer power off and then on again and returning all DIP switches to their original settings.

---

## **Setting Emulation Mode**

If you are replacing an Intermec 8636 or 8646 printer with a 3240 printer, you can keep your existing network, hardware, software, and label formats by using Emulation mode. The labels your 3240 printer produces will look just like the ones that your 86XX printer prints.

There are three ways to set the printer to Emulation mode:

- Use PrintSet to select either 100 dpi (10 mil) or 66 dpi (15 mil) mode. For help, see the PrintSet online help.
- Use the IPL command set to select Emulation mode. For help, see the *IPL Programming Reference Manual*.
- Use the DIP switches in the Test and Service DIP switch bank. For help, see the following procedure.

### **To set the printer to Emulation mode using DIP switches**

1. Upload label formats, fonts, and graphics from the 8636 or 8646 printer to the host computer.
2. Turn the printer ON/OFF switch to the off position.
3. Disconnect the 86XX printer and install the 3240 printer. (See Chapter 1 for information on installing the 3240 printer.)
4. Press and hold the Feed/Pause button while turning on the printer.

The printer prints out a hardware configuration label and then enters Data Line Print mode.

5. In the top bank of the Test and Service mode DIP switches, turn on switches 1 and 3 and turn off switch 2.

6. Use the table below to help you choose the appropriate DIP switch settings:

<b>Setting</b>	<b>Description</b>
86XX 10 mil	The printer emulates an 8636 or 8646 printer printing multiples of 10 mil (0.01 inch) drag and 10 mil (0.01 inch) picket bar codes.
86XX 15 mil	The printer emulates an 8636 or 8646 printer printing multiples of 10 mil (0.01 inch) drag and 15 mil (0.015 inch) picket bar codes.
Advanced 5 mil	The printer uses the 3240 command set and prints in multiples of 5 mil (0.005 inch) drag and 5 mil (0.005 inch) picket bar codes.
Advanced 2.5 mil (default)	The printer uses the 3240 command set and prints in multiples of 2.5 mil (0.0025 inch) drag and 2.5 mil (0.0025 inch) picket bar codes.

To enable 10 mil emulation, turn on DIP switch 4 and turn off DIP switch 5.

To enable 15 mil emulation, turn on DIP switches 4 and 5.

To enable 5 mil Advanced mode, turn off DIP switches 4 and 5.

To enable 2.5 mil Advanced mode, turn off DIP switch 4 and turn on DIP switch 5.

7. Press the Feed/Pause button.

The printer prints out the software configuration label. Verify that the label states the correct mode.

8. Turn the printer off and then on again.

9. Download the 86XX formats, fonts, and graphics from the host to the 3240 printer.

## ***Replacing an 86XX, 4100, or 3400 Printer With a 3240 Printer***

---

The 3240 printer provides compatibility with the 3400 printer, the 4100 printer, and the earlier 8636 and 8646 bar code printers. The 3240 printer operates in Advanced mode or 86XX Emulation mode. The two modes have three operational subset modes: Print mode (contains configuration commands), Program mode, and Test and Service mode.

Both Advanced mode and 86XX Emulation mode operate on the same basic command set for print, configuration, program, and test and service commands. On initial power up, the 3240 printer is in Advanced mode. Advanced mode provides new features that make the 3240 compatible with the 4100 and 3400 printers. When you select 86XX Emulation mode, the 3240 printer is compatible with the 8636 and 8646 printers. In 86XX Emulation mode, some of the Advanced mode features are not available.

---

### ***Differences Between 86XX Printers and 86XX Emulation***

While the 3240 printer can emulate most functions of the 86XX series printers, there are some features that are different or not implemented. This section identifies those differences.

#### ***No BEL Status Response***

The 86XX printer checks all incoming messages for errors before storing them in the data buffer for later execution. When it receives an erroneous message, it sends a BEL character back to the host as the printer status response and discards the whole message. It continues to process the next message without explaining to the host why it discards the previous message.

The 3240 printer software does not ignore messages that have errors in any of the commands. Instead, it executes all the commands as best as it can, ignoring invalid commands and using printer defaults for erroneous parameters. As a result, the printer treats mandatory data fields like optional data fields. Attempting to execute all commands, in spite of errors, gives the user clues about what went wrong and what they can do to remedy the problem.

Even though the 3240 printer does not send the BEL status response back to the host, it still generates the internal error code like the 86XX printer. The user can use the same command to ask the printer to transmit its latest error code to the host. The 86XX Emulation mode or Advanced mode setting does not affect this feature of the 3240 printer.

***Prints Erroneous Labels***

An 86XX printer does not print a label if the printed image does not fit within the boundaries of the label stock. The 3240 printer prints the label, even if the label is incomplete or the image overruns the next label. If the printer overruns the next label, the printer form feeds to the following label before the next print.

***Limited User-Defined Protocol***

The 3240 printer provides the capability to change protocol characters. However, unlike the 86XX printer, you cannot define your own protocol. You can substitute characters to use as protocol characters, but the rules for the protocol chosen do not change. The printer does not use any protocol character that you replace by the NUL character. One table of protocol characters exists. You can redefine these characters and all protocols will use them.

For example, you can redefine protocol characters by replacing control characters with printable characters. Use caution since you cannot replace a control character with more than one printable character.

The following table lists the protocol characters that you may redefine and which protocols they affect.

Character	Protocols Affected		
SELECT IN		POL Mode D,	Multi-Drop
POLL IN		POL Mode D,	Multi-Drop
RES IN		POL Mode D,	Multi-Drop
REQ IN		POL Mode D,	Multi-Drop
SOM IN	STD,	POL Mode D,	Multi-Drop, XON/XOFF
EOM IN	STD,	POL Mode D,	Multi-Drop, XON/XOFF
AFF IN		POL Mode D,	Multi-Drop
NEG IN		POL Mode D,	Multi-Drop
DLE IN	STD,	POL Mode D,	Multi-Drop, XON/XOFF
XON IN			XON/XOFF
XOFF IN			XON/XOFF
SELECT OUT			Multi-Drop
POLL OUT			Multi-Drop
RES OUT		POL Mode D,	Multi-Drop
REQ OUT		POL Mode D,	Multi-Drop
SOM OUT		POL Mode D,	Multi-Drop
EOM OUT		POL Mode D,	Multi-Drop
AFF OUT		POL Mode D,	Multi-Drop
NEG OUT	STD,	POL Mode D,	Multi-Drop
DLE OUT	STD,	POL Mode D,	Multi-Drop, XON/XOFF
XON OUT			XON/XOFF
XOFF OUT		POL Mode D,	Multi-Drop, XON/XOFF
PROTO-CMD 1	STD		XON/XOFF
PROTO-CMD 2	STD		XON/XOFF
TIMEOUT ON EOM		POL Mode D,	Multi-Drop

***Added Auto-Transmit 3 and SI Configuration Commands***

When you enable the Auto-Transmit 3 status response, the printer will automatically transmit image overrun, print job complete, buffer empty, and insufficient RAM status when they occur. An entire set of configuration commands beginning with the SI (0x0F) character is available.

***Increased Storage Capacity***

86XX printers provide a maximum of less than 5.5K of memory for format storage. 3240 printers provide up to 120K for configuration, formats, fonts, and UDCs (without memory expansion option). The maximum number of formats increases from 10 to 20. Fields per format have increased from 100 to 200. The maximum data buffer size for a field increases from 50 to 200. The number of UDCs increases from 10 to 100. The number of user-defined fonts increases from 7 to 16.

***Features Not Implemented***

The 3240 printer does not implement some features of the 86XX printers. These features include:

- Breach printing (eliminated on “speeded up 86XX printer”). You can achieve the same functionality by defining the format, rotated 180 degrees, in a page.
- Printhead size command.
- 8100 protocol and command set.
- Mandatory data fields. The 3240 printer prints a label even if data is missing from mandatory data fields.
- Prompting mode.

---

## ***Differences Between the 3240 Printer and the 4100 Printer***

The 3240 printer has many of the same features and functions as the 4100 printer. Use this section of the manual to identify the features that function differently or are not implemented on the 3240 printer.

### ***DIP Switches***

#### **4100 Printer DIP Switches**

The 4100 printer has DIP switches to select the number of stop bits, to enable self-strip and Test and Service, and to select baud rates of 110, 300, and 600.

The 4100 printer has DIP switches to support even, odd, mark, and space parities.

The 4100 printer has DIP switches to specify Intermec protocols.

A front panel switch allows you to select between direct thermal or thermal transfer media on the 4100 printer.

#### **3240 Printer DIP Switches**

The 3240 printer does not provide DIP switches for these parameters.

The 3240 printer supports even, off, and non parities.

3240 DIP switches allow selection between Intermec Standard or XON/XOFF protocol, and between XON/XOFF No Status Protocol. The 3240 printer can automatically detect when the Intermec protocol is in use.

The 3240 printer provides a DIP switch for this selection.

### ***Communications***

The 3240 printer does not support baud rates below 1200 baud. It does not allow selection of number of stop bits. It uses one stop bit. The 3240 printer does not support mark and space parity.

### ***Entering Test and Service Mode***

With the 4100 printer, you enter Test and Service mode by setting the appropriate DIP switch and turning on the printer. The 3240 printer enters Test and Service mode when you turn on the printer while pressing the front panel button.

### ***No Cutter***

The 3240 printer does not support a cutter.

### **Front Panel**

#### **4100 Front Panel**

The 4100 printer has three front panel buttons: Pause, Feed, and Stop/Cancel.

The 4100 printer has three front panel LEDs: Power, Pause, and Paper/Ribbon (which flashes during label or ribbon faults).

#### **3240 Front Panel**

The 3240 printer has one front panel button for these three functions.

The 3240 printer has three front panel LEDs: Power, Alert, and Empty/Pause (which indicates printhead over-temperature or system failure).

### **RAM Differences**

The 4100 printer uses static RAM for both storing label entities and for editing and imaging labels. You can allocate up to 250K of storage RAM when you have the expanded RAM installed. Up to 17 image bands may be allocated for imaging with minimal storage RAM allocated.

The 3240 uses static RAM for storing label entities and a separate dynamic RAM for editing and imaging. You can allocate up to 128K of storage RAM. You can use a limited amount of static RAM along with dynamic RAM for imaging by reallocating storage RAM in the 3240 printer. When you have expanded RAM installed and the minimum amount of storage RAM allocated, you can allocate up to 7 image bands for imaging.

---

### **Differences Between the 3400 Printer and the 3240 Printer**

Intermec derived the 3240 printer firmware from the 3400 printer firmware. It uses the same commands and can receive command files and print identical labels to the 3400 printer. While most features are similar, we had to change or delete some features due to differences in the printer electronics and mechanism.

### **Printhead Size**

The 3400 printhead has 832 elements (dots) for a total of 4.16 inches. The 3240 printhead has 1024 elements for a total of 2.52 inches. The 3400 printers have printhead elements (dots) that are 0.125 mm in size, for a total of 203 dots per inch (dpi). The 3240 printer has printhead elements 0.0625 mm in size, for a total of 406 dpi.

When emulating a 3400 printer in 203 dpi mode, the 3240 printer doubles the X and Y dimensions of bar codes, lines, boxes, and graphics to emulate the larger dot size. The 3240 does not double the dimensions of human-readable characters. The resident fonts are the same size in both the 3240 and the 3400 printers. The only difference is that the characters print much more clearly on the 3240 printer.

### **Fonts**

Three Speedo outline fonts are resident in the 3240 printer: two mono-spaced fonts and one proportional font. All resident bitmap fonts are identical to the 3400 printer except that characters are smoother on the 3240 printer due to the greater printhead resolution. The software generates the characters for fonts 22 and 35 through 41 from the resident outline fonts, but the printer treats them as bitmap fonts. The fonts now include Code Page 850 and you can access it as a separate international language.

### **DPI Emulation Modes**

The 3400 printer operates under two modes: Advanced and Emulation mode. Advanced mode operates under 5 mil or 203 dpi mode. Emulation mode operates under 10 mil or 100 dpi mode and recognizes only 86XX commands. The 3240 printer operates under three modes: 406 dpi, 203 dpi, and 100 dpi. When the 3240 printer is in 100 dpi mode, it recognizes only the 86XX command set and prints at 10 mil resolution. When the 3240 printer is in 203 dpi mode, it recognizes the full IPL command set and prints at 5 mil resolution. When the printer is in 406 dpi mode (native 3240 mode), it recognizes the same command set as the 203 dpi mode but prints at 406 dpi resolution.





***Printer Reference***



## **3240 Printer Specifications**

---

This section describes the specifications and performance parameters for the 3240 printer.

### ***Dimensions (no options installed)***

Height	11 inches (27.9 cm)
Width	8.25 inches (21 cm)
Length	17 inches (43.2 cm)
Weight	32 pounds (14.5 kg)

### ***Electrical Requirements***

Input Voltage	100, 115, or 230 VAC $\pm$ 10%
Frequency	47-63 Hz

### ***Printing Method***

The 3240 printer is capable of direct thermal (DT) printing, or thermal transfer (TTR) printing using a thermal transfer ribbon.

### ***Printing Speed***

Maximum	4 inches per second (101.6 mm per second)
Minimum	2 inches per second (50.8 mm per second)

The print speed can be changed in 1 ips increments only: 2, 3, or 4.

### ***Printhead***

Printed dot size	0.0025 inch square (0.065 mm)
Width	2.5 inches maximum (63.5 mm)
Resolution	406 dots per inch (16 dots per mm)
Number of elements	1024 per printhead
“X” dimensions	5 mil to 50 mil (0.127 mm to 1.27 mm); 2.5 mil (0.06 mm) in drag mode only (specified media only)

**Media Specifications**

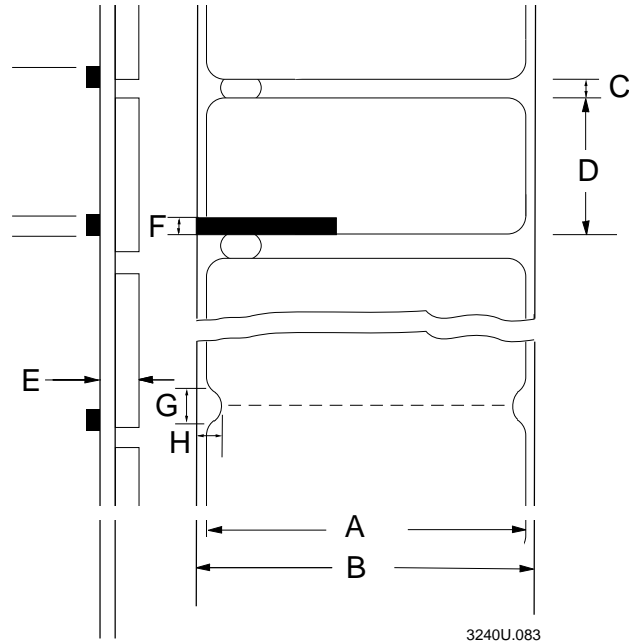

Number	Description	Minimum	Maximum
A	Label width	0.5 inch (13 mm)	2.7 inches (69 mm)
B	Backing width	0.5 inch (13 mm)	2.8 inches (71 mm)
C	Gap between labels	0.10 inch (2.5 mm)	1.0 inch (25.4 mm) plus label length
D	Label length - stripped media	0.25 inch (6.4 mm)	N/A
	Label length - butt cut media	0.25 inch (6.4 mm)	N/A
E	Media thickness	0.003 inch (0.08 mm)	0.012 inch (0.30 mm)
F	Reflective sensor mark length	0.10 inch (2.5 mm)	1.0 inch (25.4 mm)
G	Notch length	0.10 inch (2.5 mm)	1.0 inch (25.4 mm)
H	Notch width	0.15 inch (3.8 mm)	N/A
	Roll diameter		8.38 inch (213 mm)

**Ribbon Specifications**

Roll	6,000 linear inches (152 m)
Widths	1.0 inches (25 mm) 2.8 inches (71 mm)
Diameter	2.25 inches maximum (57 mm)

**Environment**

Operating	41°F to 104°F (5°C to 40°C)
Storage	-4°F to 158°F (-20°C to 70°C)
Humidity	10% to 90% with maximum wet bulb 82°F (28°C) and minimum dew point 36°F (2°C)

**Self-Strip Specifications**

The self-strip rewinder hub can take up the backing of an entire 6,000-inch roll of media with 40 lb liner (50 lb liner causes problems). You can self-strip labels as small as 0.25 inch by 0.25 inch.

Peel Release	10-50 grams
--------------	-------------

**Fonts and Graphics**

There are 21 resident bitmap scalable fonts (including OCR A and B) and three outline fonts available on the 3240 printer. Font ID 3 through 6 and 8 through 19 can be used to download user-defined fonts.

Amount of RAM	Maximum UDF or UDC
128K (standard)	2.5 inches x 2.5 inches (64 mm x 64 mm)
512K (expanded)	2.5 inches x 5 inches (64 mm x 127 mm)

**Character Sets**

US ASCII	Norwegian/Danish
UK ASCII	Swedish/Finnish
German	Italian
French	Spanish
Switzerland	Code Page 850

**Memory**

Base	Optional
512K of DRAM	512K of SRAM expanded
128K of SRAM standard	2 to 8M Kanji/Katakana memory expansion board

## Factory Default Settings

---

The following table lists the factory default settings for the 3240 printer. Use PrintSet to set these parameters. The printer's serial port defaults, which are set using the rear panel DIP switches, are described in Chapter 2, "Operating the Printer."

<b>Configuration</b>	<b>Default Setting</b>
Preamble Character	Disabled
Postamble Character	Disabled
Auto-Transmit 1	Disabled
Auto-Transmit 2	Disabled
Auto-Transmit 3	Disabled
Message Delay	0 milliseconds
Power-Up Mode	Advanced mode
End-of-Print Skip Distance	100 dots
Top of Form	20 dots
Media Sensitivity	420
Number of Image Bands	3
Maximum Label Length	1000 dots
Printer Character Set	US ASCII
Label Retract	Enabled
Print Speed	3 inches per second (ips)
Label Stock Type	Die-cut
Intercharacter Delay	0 milliseconds

## ***Communications Protocol Characters***

---

<b>Protocol Characters</b>	<b>Standard</b>	<b>XON/XOFF</b>	<b>Polling Mode D</b>	<b>Multi-Drop</b>
Select in			GS	GS
Poll in			FS	FS
Reset in			EOT	EOT
Request for Acknowledgement in			ENQ	ENQ
Start of Message in	STX	STX	STX	STX
End of Message in	ETX	ETX	ETX	ETX
Acknowledgement in			ACK	ACK
Negative Acknowledgement in		NAK	NAK	
Data Line Escape in	DLE	DLE	DLE	DLE
XON in		DC1		
XOFF in		DC3		
Select out				GS
Poll out				FS
Reset out			EOT	EOT
Request for Acknowledgement out		ENQ	ENQ	
Start of Message out			STX	STX
End of Message out			ETX	ETX
Acknowledgement out			ACK	ACK
Negative Acknowledgement out	NAK		NAK	NAK
Data Line Escape out	DLE	DLE	DLE	DLE
XON out		DC1		
XOFF out		DC3		
Status Enquiry in	ENQ	ENQ		
Status Dump in	VT	VT		
Timeout on EOM			15	15

## Configuration Parameters Upload

---

Upload configuration parameters to the printer in the form of configuration commands. The commands are concatenated into one command string within a message. Listed below is the order in which the commands are transmitted and the number of bytes in each command.

Commands	Syntax	Bytes
Set Message Delay	<ESC><SYN> <i>n</i>	6
86XX/Advanced Mode on Power-Up	<SI> <i>Cn</i>	3
Set End-of-Print Skip Distance	<SI> <i>Dn</i>	6
Set Darkness Adjust	<SI> <i>dn</i>	5
Set Top of Form	<SI> <i>Fn</i>	6
Select Media Sensitivity	<SI> <i>gn,m</i>	7
Set Number of Image Bands	<SI> <i>In</i>	4
Set Maximum Label Length	<SI> <i>Ln</i>	6
Select Printer Language	<SI> <i>ln</i>	3
Define Amount of Storage RAM	<SI> <i>Nn</i>	5
Enable/Disable Label Retract	<SI> <i>Rn</i>	3
Set Label Retract Distance	<SI> <i>rn</i>	4
Set Print Speed	<SI> <i>Sn</i>	4
Select Label Stock Type	<SI> <i>Tn</i>	3
Set Intercharacter Delay	<SYN> <i>n</i>	5
Set Preamble	<SOH> <i>n</i>	2-3
Set Postamble	<EOT> <i>n</i>	2-3
Disable Auto-Transmit 1, 2, and 3	<ESC> <i>k</i>	2
Enable Auto-Transmit 1*	<ESC> <i>j</i>	2
Enable Auto-Transmit 2*	<ESC> <i>d</i>	2
Enable Auto-Transmit 3*	<ESC> <i>e</i>	2
<b>Total bytes</b>		<b>82-84</b>

\* Only sent if enabled.

## ***Printer Functional Boundaries***

---

This section defines the boundaries and limits available to the user within the command set. Every printer function or feature has a functional limit that assumes unlimited common memory. Since several functions may compete for common memory, the memory limit may be reached before the functional limit is reached.

### ***Format Boundaries***

The following table contains the functional boundaries for 3240 label formats. If you find that you have trouble managing the printer memory, you may want to restructure your formats or purchase additional memory.

<b>Format Boundary Parameter</b>	<b>Functional Limit</b>
Bar Code Height Magnification	999
Bar Code Width Magnification	99
Characters in a Field Name	8
Characters in a Field	250 (includes field delimiters)
Field Data Offset	9999
Fields in a Format	200
Font Character Height Magnification	250
Font Character Size	2.5 inches square
Font Character Width Magnification	250
Formats	20
Formats in a Page	26
Increment or Decrement Value	9999
Line Length	9999
Line Width	9999
Pages	10
Quantity or Batch Size	9999
Slaves to a Field	20

---

**Format Boundaries (continued)**

<b>Format Boundary Parameter</b>	<b>Functional Limit</b>
User-Defined Character Height Magnification	250
User-Defined Character Size	2.5 inches square
User-Defined Character Width Magnification	250
User-Defined Characters	100
User-Defined Font Sets	16

---

**Communications Boundaries**

The following table contains the communications boundaries for the 3240 printer.

<b>Parameter</b>	<b>Functional Limit</b>
Message Delay	9999 milliseconds
Intercharacter Delay	9999 milliseconds
Message Block Size	255 (includes STX and ETX characters) (Standard protocol)
Message Size	Unlimited (XON/XOFF protocol)
Data Buffer	2K maximum
Buffer Full Point	1.5K
Device Address Number (Multi-Drop only)	A to Z, 0 to 5

## ***Printer Options***

---

This page contains a list of all the options you can use with the 3240 printer along with a brief description. Consult your Intermecc representative to order any option.

---

### ***Memory Expansion***

The memory expansion option replaces the 128K of SRAM with 512K of SRAM to hold more formats, fonts, or bitmap graphics. It also increases the printer's image buffering capabilities.

---

### ***Twinax Interface***

Use the twinax interface to connect your printer to an IBM twinax cable system with a twinax interface. Your 3240 printer emulates an IBM 5256 Model 1 printer and can operate with an IBM System/34, System/36, System/38, or AS/400 host computer.

---

### ***Coax Interface***

Use the coax interface adapter to connect your printer to an IBM 3270 Type A coax cable computer systems operating in the VTAM (CICS/IMS/TSO) or 8100 (DPPX) environments. Your 3240 printer emulates an IBM 3287 printer and you can connect it to an IBM 3174/76/99 system controller/multiplexer.

---

### ***Batch Takeup***

Batch takeup automatically spools labels as they are printed. This attachment is limited to small batches with a maximum outer diameter (OD) of 5 inches.

---

### ***Kanji/Katakana***

This option allows the 3240 printer to print Japanese characters in two Kanji fonts and three Katakana fonts.

---

## **Centronics Parallel Interface**

Intermec does not provide a cable for use with the parallel interface. You can either buy one from your local computer store or use the following information to make your own interface cable. The parallel interface only allows one-way communications with the printer. You may download from the host terminal, but you cannot upload from the printer.

The following pin descriptions are for the printer's parallel interface connector:

<b>Signal</b>	<b>Pin</b>	<b>Return</b>	<b>Direction</b>	<b>Description</b>
DATASTB	1	19	IN	Negative pulse. Latches DB0-7 on the rising edge. Eight bits in parallel provide data input. High is logical 1 and LOW is logical 0.
DB0	2	20	IN	
DB1	3	21	IN	
DB2	4	22	IN	
DB3	5	23	IN	
DB4	6	24	IN	
DB5	7	25	IN	
DB6	8	26	IN	
DB7	9	27	IN	
ACK	10	28	OUT	Negative pulse. Data has been received.
BUSY	11	29	OUT	If HIGH, printer cannot receive data.
PE	12	30	OUT	If HIGH, out of ribbon or media.
SELECT	13	-	OUT	Pulled to +5V. Printer is on.
CHASSIS GND	17	-	-	Printer's chassis ground isolated from logic ground.
INIT	31	16	IN	Clears I/OINT0 latch.
FAULT	32	33	OUT	See printer display.

**Note:** The maximum cable length for a parallel interface is 10 feet.

## Bar Code Symbolologies

---

Most of the following information has been taken out of *The Bar Code Book* by Roger C. Palmer (Intermec Part No. 051241). The 3240 printer can print a bar code on a label in any of the following symbolologies:

Bar Code	Description
Codabar	A bar code symbology that is variable length, discrete, and self-checking. It requires close printing tolerances. It is used in department store price labeling, libraries, medicine, photofinishing envelopes, air bills, and American Blood Commission blood tags. The character set is limited to 16 characters: 0 – 9, dollar sign (\$), colon (:), period (.), slash (/), plus (+), and minus (-). Its maximum density is 12.8 characters per inch.
Code 2 of 5	A discrete, self-checking code for encoding numeric data only. The bars encode information and the spaces separate individual bars. It can achieve densities of 15 characters per inch. The Nieaf Company in the Netherlands developed Code 2 of 5.
Code 11	A high-density, discrete, numeric bar code developed by Intermec. The character set includes the numbers 0 through 9 and the dash character (-). Each character is represented by a standalone group of three bars with two included spaces. This code is not self-checking. One or two check digits provide data security. Code 11 is widely used in labeling telecommunications equipment. Its maximum density is 15 characters per inch.
Code 16K	A two-dimensional (stacked rows) ultra-high density bar code that has loose printing tolerances. Code 16K is based on Code 128 (128 squared is 16,384 or 16K). It requires a check digit. Code 16K is widely used in labeling unit-dose packaging for the healthcare industry; it is suitable for labeling small objects because it can encode more data in less area than many other codes. The character set includes all 128 ASCII characters.
Code 39	An alphanumeric bar code symbology that is discrete, variable length, and self-checking. It requires loose printing tolerances. It is used in manufacturing, government agencies, and healthcare. The character set is A – Z uppercase, 0 – 9, dollar sign (\$), period (.), slash (/), percent (%), space ( ), plus (+), and minus (-). It can be extended to full 128 character ASCII by use of a two-character encoding scheme (see full ASCII). Its maximum density is 9.8 characters per inch.
Code 49	A bar code symbology that is multirow, fixed length, and continuous. It requires loose printing tolerances. It is suitable for labeling small objects because it can encode more data in less area than other codes. The character set is all 128 ASCII characters. Its maximum density is 93.3 alphanumeric characters per inch or 154.3 numeric characters per inch.

---

**Bar Code Symbolologies (continued)**

<b>Bar Code</b>	<b>Description</b>
Code 93	A bar code symbology that is discrete, variable length, and self-checking. It requires loose printing tolerances. It can be used interchangeably with Code 39 when higher density printing is required. The character set is the same as Code 39: A – Z uppercase, 0 – 9, dollar sign (\$), period (.), slash (/), percent (%), space ( ), plus (+), and minus (-). It can be extended to full 128 character ASCII by use of a four-character encoding scheme (see Full ASCII). Its maximum density is 14.8 characters per inch.
Code 128	A variable length, continuous, and weakly self-checking bar code developed by Computer Identics. It requires loose printing tolerances. Its high density makes it useful when printing data in a limited space. The character set includes all 128 ASCII characters. Each character is represented by 11 modules and four bar widths. Its maximum density is 12.1 alphanumeric characters per inch or 24.2 numeric characters per inch.
Code One	A 2D matrix symbology that is especially useful for applications such as small parts labels that do not provide sufficient space for linear bar codes. In addition to data storage and error correction symbols, each Code One symbol contains a set of horizontal lines in the center, called a finder pattern, that helps readers quickly locate and identify each symbol. Code One symbols also contain vertical reference bars to help readers locate the relative positions of each data bit.
Data Matrix	Data Matrix is a 2D matrix symbology which is made up of square modules arranged within a perimeter finder pattern. The finder pattern is a perimeter to the data region and is one module wide. Two adjacent sides are solid dark lines. These lines are used to define physical size, orientation, and symbol distortion.
EAN	European Article Numbering; now also called IAN (International Article Numbering). International standard bar code for retail food packages corresponding to the Universal Product Code (UPC) in the United States. UPC is a subset of EAN, and a reader equipped to read EAN can also read UPC. A reader equipped to read UPC may not decode EAN. The EAN and UPC symbols were developed by IBM and introduced into the market in 1971. The U.S. adopted UPC in 1973; EAN was adopted in 1976.
HIBC	Health Industry Bar Code standard. A modified version of Code 39 that has 43 characters, utilizes the Modulus 43 check character, and reserves some character combinations for special usage.
Interleaved 2 of 5	A bar code developed by Intermec for Computer Identics that encodes the ten digits 0 through 9. The name Interleaved 2 of 5 is derived from the method used to encode two characters. In this symbol, two characters are paired, using bars to represent the first character and the interleaved spaces to represent the second character. Each character has two wide elements and three narrow elements, for a total of five elements. The specification for this bar code is set forth in MHI/AIR USD-1. It can achieve a maximum density of 7.8 characters per inch.

---

**Bar Code Symbolologies (continued)**

<b>Bar Code</b>	<b>Description</b>
Maxicode	Maxicode is a fixed-size symbology where height and width magnification is ignored. This symbology is made up of offset rows of hexagonal elements arranged around a bull's-eye finder pattern. Each hexagon represents one bit of information and is either black or white depending on the state of the encoded data bit. United Parcel Service (UPS) developed Maxicode for the specific purpose of encoding information about a parcel.
PDF417	A 2D stacked symbology. Each row includes start/stop characters, row identifiers, and symbol characters, which consist of four bars and four spaces each and contain the actual data. PDF417 provides an extensive error detection and correction option that can recover up to 510 characters lost due to a damaged label or to an error in scanning.
POSTNET	The Postal Numeric Encoding Technique (POSTNET) was developed by the U.S. Postal Service to provide an optimized bar code system for encoding ZIP code information on letter mail so that the encoded information may be reliably read and decoded by optical reading systems. POSTNET utilizes redundant information within a compact bar code format to provide error detection capability and a significant degree of error correction capability.
UPC	Encodes the number system character (type of encoded product), five-digit manufacturer number assigned by the UPCC, five-digit product code assigned by the manufacturer, and a modulus 10 check digit as the 11th character. The code is numeric, and there are other versions. Nominal dimensions for the UPC symbol include a module width of 13 mils (+-) 4 mils. Magnification factors range from 0.80 to 2.00 of nominal supporting densities of 10.21 to 4.08 characters per inch, with a nominal of 8.17 characters per inch.

## International Character Sets

The following tables show which hex codes to download for international characters not available in the U.S. character set. To use the tables, find the hex code for the U.S. character that corresponds with the character in your language.

### Advanced Character Table

If you are running your printer in Advanced mode (you are not using 86XX Emulation), use this table to find the right hex codes for the international character sets.

	23	24	40	5E	5C	5D	5E	60	7E	7C	7D	7E
U.S. ASCII	#	\$	@	[	\	]	^	`	{		}	~
U.K. ASCII	£	\$	@	[	\	]	^	`	{		}	-
Germany	#	\$	§	Ä	Ö	Ü	^	`	ä	ö	ü	ß
France	£	\$	à	°	ç	§	^	`	é	ù	è	_
Norway/Denmark	#	\$	@	Æ	Ø	Å	^	`	æ	ø	å	..
Sweden/Finland	#	Ï	É	Ä	Ö	Å	Ü	é	ä	ö	å	ü
Spain	£	\$	§	í	Ñ	¿	^	`	°	ñ	ç	~
Switzerland	#	\$	à	°	ç	é	^	ù	ä	ö	ü	è
Italy	£	\$	§	°	ç	é	^	ù	à	ò	è	ì



### 86XX Character Table

This table shows the hex codes for the character sets that print if your printer is running under 86XX Emulation mode.

	23	24	40	5B	5C	5D	5E	60	7B	7C	7D	7E
U.S. ASCII	#	\$	@	[	\	]	^	`	{		}	~
U.K. ASCII	£	\$	@	[	\	]	^	`	{		}	~
Germany	#	\$	§	Ä	Ö	Ü	^	`	ä	ö	ü	ß
France	£	\$	à	°	ç	§	^	`	é	ù	è	¨
Norway/Denmark	#	\$	@	Æ	Ø	Å	^	`	æ	ø	å	~
Sweden/Finland	#	¤	É	Ä	Ö	Å	Ü	é	ä	ö	å	ü
Spain	Pt	\$	@	¡	Ñ	¿	^	`	¨	ñ	ç	~
Switzerland	#	\$	à	°	ç	é	^	ù	ä	ö	ü	è
Italy	#	\$	§	°	ç	é	^	ù	à	ò	è	ì

### IBM Translation Character Table

If you are running your printer with IBM Translation enabled, use this table to find the right hex codes for the international character sets.

	4F	7B	5B	7C	4A	E0	5A	5F	79	C0	6A	D0	A1
U.S. ASCII		#	\$	@	ç	\	!	¬	`	{		}	~
U.K. ASCII		#	£	@	§	\	!	¬	`	{		}	_
Germany	!	#	\$	§	Ä	Ö	Ü	^	`	ä	ö	ü	ß
France	!	£	\$	à	°	ç	§	^	`	é	ù	è	¨
Norway/Denmark	!	Æ	Å	Ø	#	\	¤	^	`	æ	ø	å	ü
Sweden/Finland	!	Ä	Å	Ö	§	É	¤	^	é	ä	ö	å	ü
Spain		Ñ	Pt	@	[	\	]	¬	`	{	ñ	}	¨
Switzerland	!	#	\$	à	°	ç	é	^	ù	ä	ö	ü	è
Italy	!	£	\$	§	°	ç	é	^	ù	à	ò	è	ì

## Code Page 850 Character Table

00	☺	☹	♥	♠	♣	♠	●	◻	○	◼	♂	♀	♪	♫	☀	
10	▶	◀	↕	!!	¶	§	▬	↕	↑	↓	→	←	↔	▲	▼	
20	!	"	#	\$	%	&	'	(	)	•	+	,	-	.	/	
30	0	1	2	3	4	5	6	7	8	9	:	;	<	=	>	?
40	@	A	B	C	D	E	F	G	H	I	J	K	L	M	N	O
50	P	Q	R	S	T	U	V	W	X	Y	Z	[	\	]	^	-
60	·	a	b	c	d	e	f	g	h	i	j	k	l	m	n	o
70	p	q	r	s	t	u	v	w	x	y	z	{		}	~	□
80	Ç	ü	é	â	ä	à	á	ç	ê	ë	è	ï	î	ì	Ä	Å
90	É	æ	Æ	ô	ö	ò	û	ù	ÿ	Ö	Ü	ø	£	Ø	X	f
A0	á	í	ó	ú	ñ	Ñ	ã	õ	¿	®	¬	½	¼	¡	«	»
B0	¡	¡	¡	¡	¡	Á	Â	Ã	©	¶	¶	¶	¶	¢	¥	¬
C0	⌞	⌞	⌞	⌞	+	ã	Ã	⌞	⌞	⌞	⌞	⌞	=	≠		
D0	ð	Ð	Ê	Ë	È	Ì	Í	Î	Ï	⌞	⌞	⌞	⌞	⌞	⌞	⌞
E0	Ó	Ë	Ô	Ò	õ	Õ	µ	þ	þ	Ú	Û	Ù	ý	Ý	-	'
F0	-	±	=	¾	¶	§	÷	•	◦	••	•	1	3	2	■	
F1												FB	FC	FD	FE	FF

3240U.081



## Extended Character Sets

Each internal font in the 3240 has a different character set associated with it as shown in the following tables. The hex codes accompany each character.

**Characters in Fonts**  
*c0* 7 x 9 Standard  
*c1* 7 x 11 OCR  
*c2* 10 x 14 Standard

NL	SH	SH	EH	ET	EQ	AK	BL	BS	HT	LF	UT	FF	CR	SO	SI
00	01	02	03	04	05	06	07	08	09	0A	0B	0C	0D	0E	0F
DL	DI	DE	D3	D4	NK	SN	EB	CN	EM	SB	EC	FS	CS	RS	US
10	11	12	13	14	15	16	17	18	19	1A	1B	1C	1D	1E	1F
	!	"	#	#	%	&	'	(	)	*	+	,	-	.	/
20	21	22	23	24	25	26	27	28	29	2A	2B	2C	2D	2E	2F
0	1	2	3	4	5	6	7	8	9	:	;	<	=	>	~
30	31	32	33	34	35	36	37	38	39	3A	3B	3C	3D	3E	3F
@	A	B	C	D	E	F	G	H	I	J	K	L	M	N	O
40	41	42	43	44	45	46	47	48	49	4A	4B	4C	4D	4E	4F
P	Q	R	S	T	U	V	W	X	Y	Z	[	\	]	<	
50	51	52	53	54	55	56	57	58	59	5A	5B	5C	5D	5E	5F
'	a	b	c	d	e	f	g	h	i	j	k	l	m	n	o
60	61	62	63	64	65	66	67	68	69	6A	6B	6C	6D	6E	6F
p	q	r	s	t	u	v	w	x	y	z	{		}	~	■
70	71	72	73	74	75	76	77	78	79	7A	7B	7C	7D	7E	7F
R	á	■	□	△	△										
80	81	82	83	84	85	86	87	88	89	8A	8B	8C	8D	8E	8F
90	91	92	93	94	95	96	97	98	99	9A	9B	9C	9D	9E	9F
	i		ó	õ	ÿ		š	·							~
A0	A1	A2	A3	A4	A5	A6	A7	A8	A9	AA	AB	AC	AD	AE	AF
°															~
B0	B1	B2	B3	B4	B5	B6	B7	B8	B9	BA	BB	BC	BD	BE	BF
				ñ	ñ	ñ			ñ						
C0	C1	C2	C3	C4	C5	C6	C7	C8	C9	CA	CB	CC	CD	CE	CF
	z					ö		ø				ü			ß
D0	D1	D2	D3	D4	D5	D6	D7	D8	D9	DA	DB	DC	DD	DE	DF
'			á	á	á	š	š	š	š		ö	í			
E0	E1	E2	E3	E4	E5	E6	E7	E8	E9	EA	EB	EC	ED	EE	EF
	š	ö				ö		ø	ü			ü			
F0	F1	F2	F3	F4	F5	F6	F7	F8	F9	FA	FB	FC	FD	FE	FF

3240U.066

Characters in Font c7 5 x 7 Standard

NL 00	SH 01	SX 02	EX 03	ET 04	EQ 05	AK 06	BL 07	BS 08	HT 09	LF 0A	UT 0B	FF 0C	CR 0D	SO 0E	SI 0F
DL 10	DI 11	D2 12	D3 13	D4 14	NR 15	SN 16	EB 17	CN 18	EM 19	SB 1A	EC 1B	FS 1C	GS 1D	RS 1E	US 1F
	-	=	#	#	%	+	'	^	^	* 2A	+	' 2C	 2D	. 2E	/ 2F
0 30	1 31	2 32	3 33	4 34	5 35	6 36	7 37	8 38	9 39	:	; 3B	< 3C	= 3D	> 3E	? 3F
0 40	P 41	Q 42	R 43	S 44	T 45	U 46	V 47	W 48	X 49	Y 4A	Z 4B	[ 4C	] 4D	^ 4E	_ 4F
P 50	Q 51	R 52	S 53	T 54	U 55	V 56	W 57	X 58	Y 59	Z 5A	[ 5B	\ 5C	] 5D	> 5E	_ 5F
' 60	a 61	b 62	c 63	d 64	e 65	f 66	g 67	h 68	i 69	j 6A	k 6B	l 6C	m 6D	n 6E	o 6F
p 70	q 71	r 72	s 73	t 74	u 75	v 76	w 77	x 78	y 79	z 7A	{ 7B	 7C	} 7D	~ 7E	█ 7F
R 80															
90	91	92	93	94	95	96	97	98	99	9A	9B	9C	9D	9E	9F
A0	· A1	· A2	· A3	· A4	· A5	· A6	· A7	· A8	· A9	· AA	· AB	· AC	· AD	· AE	· AF
0 B0															? BF
				· C4	· C5	· C6			· C9						
D0	Z D1					· D6		· D8				· DC			· DF
· E0				· E4		· E6	· E7	· E8	· E9		· EB	· EC			
F0	· F1	· F2				· F6	· F7	· F8	· F9			· FC			

3240U.067



**Characters in Fonts**

- c20** 8 point
- c21** 12 point
- c22** 20 point
- c25** *Swiss Mono 721 standard outline font*
- c26** *Swiss Mono 721 bold outline font*
- c28** *Dutch Roman 801 proportional outline font*
- c30-c41** *monospace fonts (6 point to 36 point)*

ØØ	Ø1	Ø2	Ø3	Ø4	Ø5	Ø6	Ø7	Ø8	Ø9	ØA	ØB	ØC	ØD	ØE	ØE
1Ø	11	12	13	14	15	16	17	18	19	1A	1B	1C	1D	1E	1F
2Ø	!	"	#	\$	%	&	'	(	)	*	+	,	-	.	/
3Ø	0	1	2	3	4	5	6	7	8	9	:	;	<	=	>
4Ø	@	A	B	C	D	E	F	G	H	I	J	K	L	M	N
5Ø	P	Q	R	S	T	U	V	W	X	Y	Z	[	\	]	^
6Ø	`	a	b	c	d	e	f	g	h	i	j	k	l	m	n
7Ø	p	q	r	s	t	u	v	w	x	y	z	{		}	~
8Ø															
9Ø															
AØ	ı	¢	£	¤	¥	¦	§	¨	©	ª	«	¬	-	®	¯
BØ	±	²	³	´	µ	¶	·	¸	¹	º	»	¼	½	¾	¿
CØ	À	Á	Â	Ã	Ä	Å	Æ	Ç	È	É	Ê	Ë	Ì	Í	Î
DØ	Ð	Ñ	Ò	Ó	Ô	Õ	Ö	×	Ø	Ù	Ú	Û	Ü	Ý	Þ
EØ	à	á	â	ã	ä	å	æ	ç	è	é	ê	ë	ì	í	î
FØ	ø	ñ	ò	ó	ô	õ	ö	÷	ø	ù	ú	û	ü	ý	þ

3240U.068

**Note:** You cannot print these characters as 2.5 x 2.5 inch graphics. White space surrounds each character and prevents it from reaching the maximum size.

Characters in Font c23 OCR A

00	01	02	03	04	05	06	07	08	09	0A	0B	0C	0D	0E	0F
10	11	12	13	14	15	16	17	18	19	1A	1B	1C	1D	1E	1F
	!	"	#	\$	%	&	'	(	)	*	+	,	-	.	/
20	21	22	23	24	25	26	27	28	29	2A	2B	2C	2D	2E	2F
0	1	2	3	4	5	6	7	8	9	:	;	<	=	>	?
30	31	32	33	34	35	36	37	38	39	3A	3B	3C	3D	3E	3F
Q	A	B	C	D	E	F	G	H	I	J	K	L	M	N	O
40	41	42	43	44	45	46	47	48	49	4A	4B	4C	4D	4E	4F
P	Q	R	S	T	U	V	W	X	Y	Z	[	\	]	^	_
50	51	52	53	54	55	56	57	58	59	5A	5B	5C	5D	5E	5F
H	a	b	c	d	e	f	g	h	i	j	k	l	m	n	o
60	61	62	63	64	65	66	67	68	69	6A	6B	6C	6D	6E	6F
p	q	r	s	t	u	v	w	x	y	z	{		}	~	■
70	71	72	73	74	75	76	77	78	79	7A	7B	7C	7D	7E	7F
80	81	82	83	84	85	86	87	88	89	8A	8B	8C	8D	8E	8F
90	91	92	93	94	95	96	97	98	99	9A	9B	9C	9D	9E	9F
A0	A1	A2	£	A4	¥	A6	A7	A8	A9	AA	AB	AC	AD	AE	AF
B0	B1	B2	B3	B4	B5	B6	B7	B8	B9	BA	BB	BC	BD	BE	BF
C0	C1	C2	C3	Ä	Å	Æ	C7	C8	C9	CA	CB	CC	CD	CE	CF
D0	Ñ	D2	D3	D4	D5	Ö	Ø	D8	DA	DB	DC	DD	DE	DF	
E0	E1	E2	E3	E4	E5	E6	E7	E8	E9	EA	EB	EC	ED	EE	EF
F0	F1	F2	F3	F4	F5	F6	F7	F8	F9	FA	FB	FC	FD	FE	FF

3240U.069



Characters in Font **c24** *OCR B Size 2*

00	01	02	03	04	05	06	07	08	09	0A	0B	0C	0D	0E	0F
10	11	12	13	14	15	16	17	18	19	1A	1B	1C	1D	1E	1F
20	!	"	#	\$	%	&	'	(	)	*	+	,	-	.	/
30	0	1	2	3	4	5	6	7	8	9	:	;	<	=	>
40	@	A	B	C	D	E	F	G	H	I	J	K	L	M	N
50	P	Q	R	S	T	U	V	W	X	Y	Z	[	\	]	^
60	`	a	b	c	d	e	f	g	h	i	j	k	l	m	n
70	p	q	r	s	t	u	v	w	x	y	z	{		}	~
80															
90															
A0			£	¤	¥	¦	§	¨							
B0				'											
C0				À	Á	Â									
D0		Ñ				Ö		Ø				Ü			ß
E0				ä	å	æ									
F0		ñ			ö			ø				ü			

3240U.070

# DIP Switch Settings

Top Bank Switch Number

O = OFF  
1 = ON

<b>Baud Rate Selection</b>							
19,200	0	0	0				
9,600*	1	0	0				
4,800	0	1	0				
2,400	1	1	0				
1,200	0	0	1				
reserved	1	0	1				
reserved	0	1	1				
reserved	1	1	1				
<b>Parity Selection</b>							
Even*				0	0		
Odd				1	0		
None				0	1		
None				1	1		
<b>Number of Data Bits</b>							
7 Bit							0
8 Bit							1
<b>Reserved</b>							0 0

Default settings are noted with an \*

Bottom Bank Switch Number

O = OFF  
1 = ON

<b>Multi-Drop Address Selection</b>							
*A	0	0	0	0	0		
B	1	0	0	0	0		
C	0	1	0	0	0		
D	1	1	0	0	0		
E	0	0	1	0	0		
F	1	0	1	0	0		
G	0	1	1	0	0		
H	1	1	1	0	0		
I	0	0	0	1	0		
J	1	0	0	1	0		
K	0	1	0	1	0		
L	1	1	0	1	0		
M	0	0	1	1	0		
N	1	0	1	1	0		
O	0	1	1	1	0		
P	1	1	1	1	0		
Q	0	0	0	0	1		
R	1	0	0	0	1		
S	0	1	0	0	1		
T	1	1	0	0	1		
U	0	0	1	0	1		
V	1	0	1	0	1		
W	0	1	1	0	1		
X	1	1	1	0	1		
Y	0	0	0	1	1		
Z	1	0	0	1	1		
0	0	1	0	1	1		
1	1	1	0	1	1		
2	0	0	1	1	1		
3	1	0	1	1	1		
4	0	1	1	1	1		
5	1	1	1	1	1		
<b>Protocol Selection</b>							
XON/XOFF*							0
Intermec Protocols							1
<b>XON/XOFF Selection</b>							
No Status Response*							0
With Status Response							1
<b>DT/ITR</b>							
Direct Thermal*							0
Thermal Transfer							1

Default settings are noted with an \*

3240U.008

# Full ASCII Chart

FULL ASCII											
Binary <sup>0</sup>	Hex <sup>1</sup>	Dec <sup>2</sup>	C39 <sup>3</sup>	Char <sup>4</sup>	Binary	Hex	Dec	C39	Char	Control	Character Definitions <sup>5</sup>
00000000	00	00	%U	NUL	01000000	40	64	%V	@	NUL	Null, or all zeros
00000001	01	01	\$A	SOH	01000001	41	65	A	A	SOH	Start of Heading
00000010	02	02	\$B	STX	01000010	42	66	B	B	STX	Start of Text
00000011	03	03	\$C	ETX	01000011	43	67	C	C	ETX	End of Text
00000100	04	04	\$D	EOT	01000100	44	68	D	D	EOT	End of Transmission
00000101	05	05	\$E	ENQ	01000101	45	69	E	E	ENQ	Enquiry
00000110	06	06	\$F	ACK	01000110	46	70	F	F	ACK	Acknowledgement
00000111	07	07	\$G	BEL	01000111	47	71	G	G	BEL	Bell
00001000	08	08	\$H	BS	01001000	48	72	H	H	BS	Backspace
00001001	09	09	\$I	HT	01001001	49	73	I	I	HT	Horizontal Tab
00001010	0A	10	\$J	LF	01001010	4A	74	J	J	LF	Line Feed
00001011	0B	11	\$K	VT	01001011	4B	75	K	K	VT	Vertical Tab
00001100	0C	12	\$L	FF	01001100	4C	76	L	L	FF	Form Feed
00001101	0D	13	\$M	CR	01001101	4D	77	M	M	CR	Carriage Return
00001110	0E	14	\$N	SO	01001110	4E	78	N	N	SO	Shift Out
00001111	0F	15	\$O	SI	01001111	4F	79	O	O	SI	Shift In
00010000	10	16	\$P	DLE	01010000	50	80	P	P	DLE	Data Link Escape
00010001	11	17	\$Q	DC1	01010001	51	81	Q	Q	DC1	Device Control 1 (XON)
00010010	12	18	\$R	DC2	01010010	52	82	R	R	DC2	Device Control 2
00010011	13	19	\$S	DC3	01010011	53	83	S	S	DC3	Device Control 3 (XOFF)
00010100	14	20	\$T	DC4	01010100	54	84	T	T	DC4	Device Control
00010101	15	21	\$U	NAK	01010101	55	85	U	U	NAK	Negative Acknowledge
00010110	16	22	\$V	SYN	01010110	56	86	V	V	SYN	Synchronous Idle
00010111	17	23	\$W	ETB	01010111	57	87	W	W	ETB	End Transmission Block
00011000	18	24	\$X	CAN	01011000	58	88	X	X	CAN	Cancel
00011001	19	25	\$Y	EM	01011001	59	89	Y	Y	EM	End of Medium
00011010	1A	26	\$Z	SUB	01011010	5A	90	Z	Z	SUB	Substitute
00011011	1B	27	%A	ESC	01011011	5B	91	%K	[	ESC	Escape
00011100	1C	28	%B	FS	01011100	5C	92	%L	\	FS	File Separator
00011101	1D	29	%C	GS	01011101	5D	93	%M	]	GS	Group Separator
00011110	1E	30	%D	RS	01011110	5E	94	%N	^	RS	Record Separator
00011111	1F	31	%E	US	01011111	5F	95	%O	_	US	Unit Separator
00100000	20	32	SP	SP <sup>6</sup>	01100000	60	96	%W	␣	SP	Space
00100001	21	33	/A	!	01100001	61	97	+A	a	DEL	Delete
00100010	22	34	/B	"	01100010	62	98	+B	b		
00100011	23	35	/C	#	01100011	63	99	+C	c		
00100100	24	36	/D	\$	01100100	64	100	+D	d		
00100101	25	37	/E	%	01100101	65	101	+E	e		
00100110	26	38	/F	&	01100110	66	102	+F	f		
00100111	27	39	/G	'	01100111	67	103	+G	g		
00101000	28	40	/H	(	01101000	68	104	+H	h		
00101001	29	41	/I	)	01101001	69	105	+I	i		
00101010	2A	42	/J	*	01101010	6A	106	+J	j		
00101011	2B	43	/K	+	01101011	6B	107	+K	k		
00101100	2C	44	/L	,	01101100	6C	108	+L	l		
00101101	2D	45	/M	-	01101101	6D	109	+M	m		
00101110	2E	46	/N	.	01101110	6E	110	+N	n		
00101111	2F	47	/O	/	01101111	6F	111	+O	o		
00110000	30	48	/P <sup>7</sup>	0	01110000	70	112	+P	p		
00110001	31	49	/Q	1	01110001	71	113	+Q	q		
00110010	32	50	/R	2	01110010	72	114	+R	r		
00110011	33	51	/S	3	01110011	73	115	+S	s		
00110100	34	52	/T	4	01110100	74	116	+T	t		
00110101	35	53	/U	5	01110101	75	117	+U	u		
00110110	36	54	/V	6	01110110	76	118	+V	v		
00110111	37	55	/W	7	01110111	77	119	+W	w		
00111000	38	56	/X	8	01111000	78	120	+X	x		
00111001	39	57	/Y	9	01111001	79	121	+Y	y		
00111010	3A	58	/Z	:	01111010	7A	122	+Z	z		
00111011	3B	59	%F	;	01111011	7B	123	%P	{		
00111100	3C	60	%G	<	01111100	7C	124	%Q			
00111101	3D	61	%H	=	01111101	7D	125	%R	}		
00111110	3E	62	%I	>	01111110	7E	126	%S	~		
00111111	3F	63	%J	?	01111111	7F	127	%T <sup>8</sup>	■ <sup>9</sup>		

**Notes**

- 0 Bit positions are 76543210
- 1 Hexadecimal value
- 2 Decimal value
- 3 Code 39 character(s)
- 4 ASCII character
- 5 Hold down Control key and press key to left of definition
- 6 SP is the SPACE character
- 7 The Code 39 characters /P through /Y may be interchanged with the numbers 0 through 9
- 8 May be interchanged with %X or %Y or %Z
- 9 ■ is the DELETE character



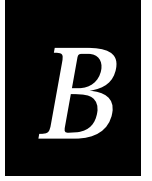

***Cabling and Communications***



## ***Communications Reference***

---

Use the following information on interfaces and protocols to integrate your 3240 printer into a data collection network.

---

### ***Host Requirements***

The 3240 printer has the following hardware and software requirements:

- The host computer must use the American Standard Code for Information Exchange (ASCII) for data communications.
- A serial port must be available on the host if you are connecting directly to the printer.
- The host must support at least one of the following data communications interfaces: RS-232, RS-422, or RS-485.

For information on configuring the host computer, port concentrator, or network controller, see the reference manual for the controlling device.

---

### ***Communications Boundaries***

The information below applies to all protocols that the printer supports.

<b>Parameter</b>	<b>Maximum Capacity</b>
Message delay	9999 milliseconds
Character delay	9999 milliseconds
Message block size	255 characters (including STX and ETX characters) Unlimited block size for XON/XOFF
Device address number (Multi-Drop only)	A to Z, 0 to 5

---

## Communications Protocols

Communications protocols are important because they determine the transmission standards for communications between the printer and the host. The 3240 and the host must use the same protocol and parameters to communicate properly. The 3240 printer supports the flow control and block transfer protocols described in the next sections. All of these protocols are point-to-point except Multi-Drop. Application programs and/or ROM BIOS determine which protocols your computer can support. For more detailed information, refer to the Intermec *Data Communications Reference Manual* (Intermec Part No. 044737).

### Intermec Standard Protocol

Intermec Standard protocol is a proprietary block transfer/status response protocol. For each block sent, the host must wait for the appropriate response before sending the next block (<DC1>). Except for single character status commands (<ENQ> and <VT>), Standard protocol transmits characters in message blocks beginning with the start of text (<STX>) character and ending with the end of text (<ETX>) character. Message blocks can be up to 255 characters, including the start of text and end of text characters. The 3440 printer auto-discriminates between Standard, Polling Mode D, and Multi-Drop protocols.

The printer returns its highest priority status when it receives a valid block (<STX> data <ETX>) or when it receives the status request command <ENQ>. When the printer receives the status dump command (<VT>), the printer returns all active status. The printer status response time ranges from 30 to 100 ms depending on the complexity of the received message block. In the case of a transmission error, the printer responds with a <NAK> and discards the entire message block.

The following table shows printer status conditions in descending order of priority, status response characters, and pin 11/20 states:

Printer Status	Character	Pin 11/20
Buffer already full	GS	Busy
Ribbon fault	US	Busy
No label stock	EM	Busy
Buffer now full	DC3	Busy
Printhead hot	SI	Busy
Offline (paused)	DC3	Busy
Label at strip pin	FS	Ready
Skipping	DC1	Ready
Printing	DC1	Ready
Ready/Online	DC1	Ready

**Note:** Do not confuse the Buffer now full <DC3> status with the XON/XOFF characters <DC1> and <DC3>.

When the printer returns Buffer Now Full (<DC3>) status, it accepts the currently received message block. At this time, the printer can accept short messages to allow parsing of immediate commands such as Reset (<DLE>) or Cancel Batch Printing (<EM>). However, if the printer responds with a <GS> to any message block, the buffer is already full and it discards the entire message block.

### ***XON/XOFF Protocol (Software and Hardware Flow Control)***

The XON/XOFF protocol stops the host from sending data when the printer buffer fills up and starts the host again when the buffer empties. When you select this protocol, you concurrently enable software and hardware flow control. Software flow control uses the ASCII characters <DC1> (XON) and <DC3> (XOFF) to start and stop the flow of data from the host to the printer. Hardware flow control uses pin 11 or pin 20 (internally connected together) on the printer's serial port to indicate "Ready" or "Busy" for data flow control. As with Standard protocol, <STX> and <ETX> enclose data. Status responses conform to the table above except that <DC2> is substituted for <DC1> and <DC4> is substituted for <DC3>.

The 3240 printer does not restrict the message length for XON/XOFF protocol. That is, the printer processes information as it is being downloaded and stops when there is no more information. There is no restriction on the number of characters that can be sent down at a time. <STX> and <ETX> are optional.

Pin 11/20 reports "Ready" and transmits a <DC1> (XON) when the printer finishes reloading at power-up. Pin 11/20 reports "Busy" when the printer's input buffer fills with 768 bytes of data. If the host ignores pin 11/20 and continues to transmit data, the printer transmits a <DC3> (XOFF) after receiving 15 additional characters. The printer continues to transmit a <DC3> after every 15 characters received if the host continues to transmit data. Data integrity is not guaranteed if this situation happens.

Pin 11/20 becomes "Ready" when the printer has transferred all the data from the input buffer. If it receives a <DC3>, the printer transmits a <DC1> (XON) and the host may resume transmission. When you switch the printer offline, pin 11/20 becomes "Busy" and it transmits a <DC3>. When you switch the printer online (and the input buffer is empty), pin 11/20 becomes "Ready" and it transmits a <DC1>.

The following table shows the printer XON/XOFF operation:

# of Bytes Received	Online/Offline	Pin 11/20	Transmit
Do not care	Offline	Busy	DC3
768	Online	Busy	DC3
768 + each 15 thereafter	Online	Busy	DC3
Buffer Empty	Online	Ready	DC1 (if DC was sent)

### ***XON/XOFF, No Status Protocol***

This protocol is identical to XON/XOFF protocol except that it does not return status after each message it receives. However, it does return status for the status request (<ENQ>) and the status dump (<VT>) commands.

### ***Polling Mode D***

Polling Mode D is a block transfer protocol that transmits data in blocks of up to 255 characters, including protocol overhead. For Polling Mode D, the host/concentrator is responsible for asking the printer for data it might have (polling) and requesting to send data to the printer (selecting). LRC characters frame the blocks for additional data integrity. Use Polling Mode D for point-to-point networks that connect the 3240 to an Intermec port concentrator (RS-232 or RS-422 are acceptable).

This protocol is the default setting for the 3240 printer. Return the protocol setting to Polling Mode D by setting the printer DIP switches to the factory default settings (9600, E, 7, 1) or by sending down the Test and Service mode command D.

### ***Multi-Drop Protocol***

Use Multi-Drop protocol to connect up to 32 devices to an Intermec controller on a four-wire RS-485 (two twisted pair). This protocol is similar to Polling Mode D except each device has a unique address (POL and SEL character). You must use an RS-485, which is automatically enabled when you enable Multi-Drop. Be sure to specify a unique address for the printer and verify that the baud rate is between 2400 and 19200.

### ***User-Defined Protocol***

The 3240 printer provides the capability to change protocol characters. However, you cannot define your own protocol. You can substitute characters to use as protocol characters, but the rules for the chosen protocol do not change. The printer does not use any protocol characters that you replace with the NUL character. One table of protocol characters exists. You may redefine these characters to create a table that all of the protocols can use. One possibility for you to redefine protocol characters may be the replacement of control characters with printable characters.

*Note: Please use caution when replacing control characters with printable characters. One control character can be replaced with only one printable character.*

The following table lists the protocol characters that you can redefine and the protocols they affect:

<b>Character</b>	<b>Protocols Affected</b>		
SELECT IN		POL Mode D,	Multi-Drop
POLL IN		POL Mode D,	Multi-Drop
RES IN		POL Mode D,	Multi-Drop
REQ IN		POL Mode D,	Multi-Drop
SOM IN	STD,	POL Mode D,	Multi-Drop, XON/XOFF
EOM IN	STD,	POL Mode D,	Multi-Drop, XON/XOFF
AFF IN		POL Mode D,	Multi-Drop
NEG IN		POL Mode D,	Multi-Drop
DLE IN	STD,	POL Mode D,	Multi-Drop, XON/XOFF
XON IN			XON/XOFF
XOFF IN			XON/XOFF
SELECT OUT			Multi-Drop
POLL OUT			Multi-Drop
RES OUT		POL Mode D,	Multi-Drop
REQ OUT		POL Mode D,	Multi-Drop
SOM OUT		POL Mode D,	Multi-Drop
EOM OUT		POL Mode D,	Multi-Drop
AFF OUT		POL Mode D,	Multi-Drop
NEG OUT	STD,	POL Mode D,	Multi-Drop
DLE OUT	STD,	POL Mode D,	Multi-Drop, XON/XOFF
XON OUT			XON/XOFF
XOFF OUT		POL Mode D,	Multi-Drop, XON/XOFF
PROTO-CMD 1	STD		XON/XOFF
PROTO-CMD 2	STD		XON/XOFF
TIMEOUT ON EOM		POL Mode D,	Multi-Drop

---

## **Communications Interfaces**

The 3240 printer supports serial communications with the following interfaces:

- RS-232
- RS-422
- RS-485

The following sections describe these interfaces. See *Data Communications Reference Manual* (Intermec Part No. 044737) for more detailed information.

### **RS-232 Serial Interface**

Use the RS-232 serial interface in all asynchronous point-to-point full- or half-duplex direct data communications or modem control. The printer cable must have the pin assignments for an RS-232 serial interface shown in the table below.

### **RS-422 Serial Interface**

Use the RS-422 interface in long line point-to-point direct connect installations. The printer cable must have the pin assignments for an RS-422 serial interface shown in the table below.

### **RS-485 Serial Interface**

Use the RS-485 serial interface for Multi-Drop installations only. The printer cable must have the pin assignments for an RS-485 serial interface shown in the following table.

---

**RS-485 Serial Interface Pin Assignments**

Interface	Pin No.	Name	Operation
RS-232/422/485	1	Chassis Ground (GND)	Connect to pin 1, chassis ground, of connected device.
RS-232	2	Transmit Data (TD)	Output: Connect to receive data pin of connected device.
RS-232	3	Receive Data (RD)	Input: Connect to transmit data pin of connected device.
RS-232/422/485	4	Request to Send (RTS)	Output: When you use a modem, connect to modem RTS pin. The connection sets RTS to true before transmission. The printer sets RTS to false after transmission.
RS-232/422/485	5	Clear to Send (CTS)	Input: When you use a modem, connect to modem CTS pin. Modem must set CTS true before the printer transmits data. If not connected, CTS sets itself true.
RS-232/422/485	7	Signal Ground (SG)	To enable communications, connect to signal ground of connected device. Completes circuit for all RS-232 signals.
RS-232/422/485	11	Printer Status (PS)	Output: When not using software flow control (XON/XOFF), connect to input of connected device (for example, CTS). Indicates printer mechanical status and status of printer input buffer.
RS-422/485	13	Input B	Input: Serial differential data to the printer.
RS-422/485	14	Output A	Output: Serial differential data from the printer.
RS-422/485	16	Input A	Input: Serial differential data to the printer.
RS-422/485	19	Output B	Output: Serial differential data from the printer.
RS-232/422/485	20	Data Terminal Ready (DTR)	Output: When you use a modem, connect to modem DTR pin.  When using Intermec Standard protocol, this pin indicates that the printer is switched on.  When using XON/XOFF or hardware flow control, this pin indicates the printer mechanical status and the status of the printer input buffer.

---

## Printer Serial Port

The rear panel of the printer contains the serial port connector. It is a 25-pin D-style subminiature receptacle. The port is wired as a data terminal equipment (DTE) device. Refer to the following figure:

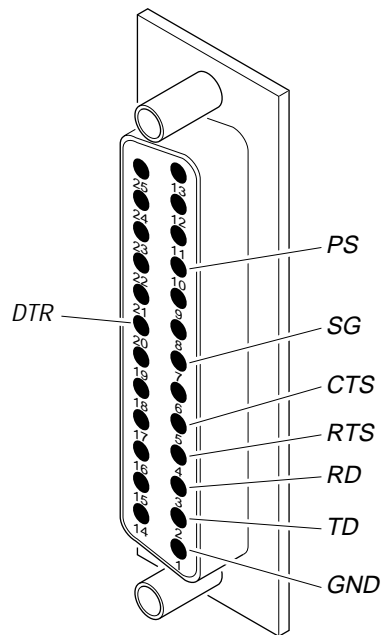

3240U.076

## ***Interface Cables and Connectors***

---

You have many different cabling options with the 3240 printer. Your choice of cabling depends on the network configuration, the hardware interface, the protocol you use, cabling distance, and the electrical and environmental conditions in which you are operating the printer. For typical installations, Intermec recommends the following cabling options:

- Shielded cable, minimum 24 gauge
- 25-pin D-style subminiature connector with metal backshell
- Cable shield connected to metal backshell
- EIA RS-232, RS-422, or RS-485 electrical interface

---

### ***Intermec Cables***

Intermec offers a full line of interface cables. You must purchase the cables separately. Contact your Intermec representative for ordering assistance. Use the following table to determine the correct cable for your application:

<b>For Connecting To</b>	<b>Use Intermec Cable Part Number</b>
IBM PC AT	048693
IBM PC XT	048668
Terminal (DTE)	047286(5)
Modem (DCE)	043237S

---

### ***Cable Schematics***

Use the cable schematics on the following pages to make your own cables.

**RS-232 Null Modem Cable for PC (Intermec Part Number 048668)**

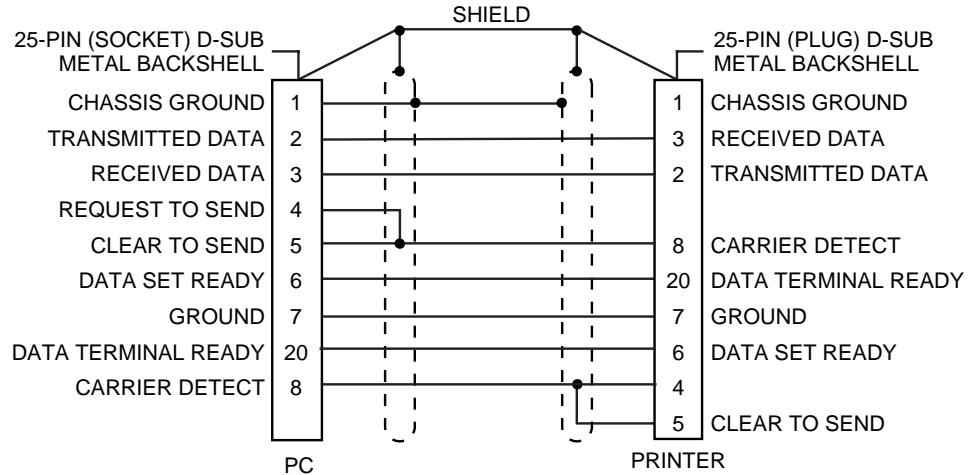

NOTE: The metal backshell is connected directly to the shield to achieve electrostatic discharge (ESD) immunity.

3240U.077

**RS-232 Null Modem Cable for AT (Intermec Part Number 048693)**

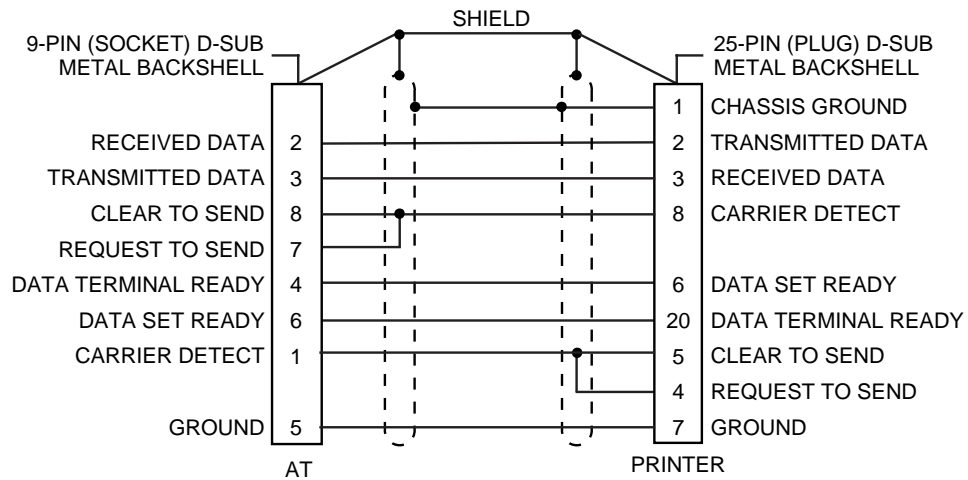

NOTE: The metal backshell is connected directly to the shield to achieve electrostatic discharge (ESD) immunity.

3240U.078

**RS-422 Software Flow Control Null Modem Cable for AT (Intermec Part Number 047286)**

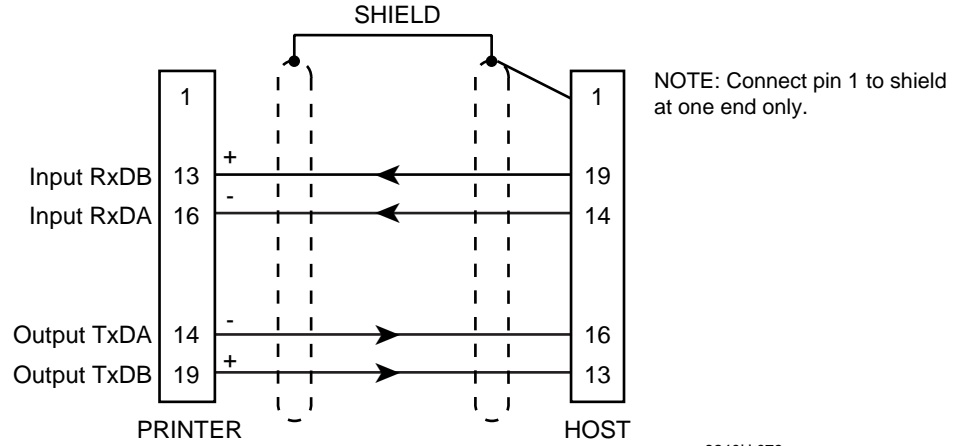

**Straight Through DTE to DCE Cable for Use with a Modem (Intermec Part Number 043237)**

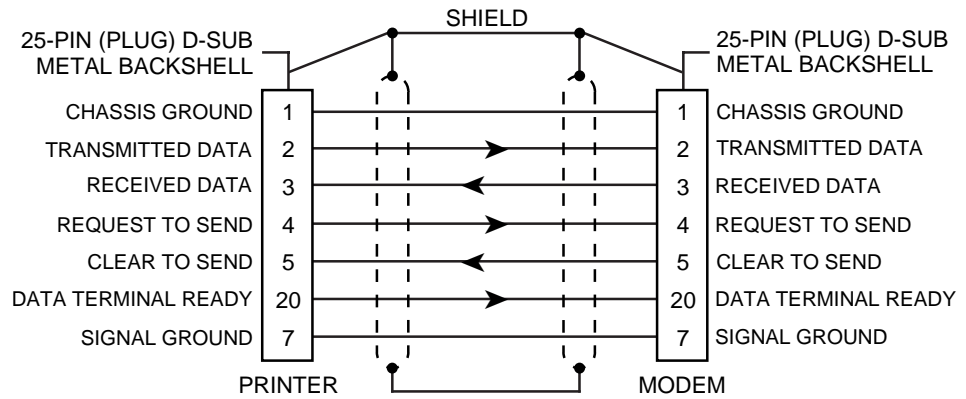

---

### ***RS-485 (Multi-Drop) Cables***

Refer to the following manuals for information on Multi-Drop cabling and connections.

- *9154 Multi-Drop Line Controller System Manual* (Intermec Part No. 048517)
- *9161B Installation Manual* (Intermec Part No. 049572)

---

### ***Cabling Considerations in Noisy Electrical Environments***

The items listed below create noisy electrical environments that can disrupt data communications between your host computer and the 3240 printer:

- Large power transformers
- Large electrical motors
- Arc welders
- Motor controllers
- Switch gears

If any of these items are near your printer, you may want to try any of the following suggestions to reduce the effects of electrical noise. If you need help eliminating noise, ask your Intermec representative for assistance.

- Always use shielded cable. Connect the cable and shield to the metal backshells on the cable connectors and fasten the connectors to the serial ports using screws.
- Install ferrite cable clamps.
- Connect the printer chassis ground to the building ground. The chassis ground is located on the ground pin of the printer power cord.

## ***Connecting the Printer to a Network or Modem***

---

The proper way to connect the 3240 printer depends on the way you configure your system. This section contains a procedure for non-switched modem installations and references for network installations.

---

### ***Modem Installation Procedure***

Use a modem to communicate with the host computer from a remote location not accessible with remote cabling. You must use an asynchronous, dedicated (non-switched or manually switched), full duplex modem. Refer to your modem documentation for communications requirements.

#### **To connect the printer to a host with a modem**

1. Connect the printer serial port to a modem using a 25-pin to 25-pin RS-232 modem cable assembly (Intermec Part No. 043237S).
2. Connect a second modem to the host computer using an appropriate cable assembly for the host and modem.
3. Connect the two modems together using an acoustic coupler or a direct connection to telephone communications lines.
4. If necessary, change the printer's serial port configuration by following the instructions in "Configuring the Serial Port" in Chapter 1.

---

### ***Network Installations***

If you are installing your printer in a network environment, you may need to change the serial port settings to match the requirements of your network. You can determine the communications requirements for your network by referring to the controlling device documentation. If the controlling device is an Intermec product, refer to the following manuals for instructions and information on the necessary cabling and connections.

- *9154 Multi-Drop Line Controller System Manual* (Intermec Part No. 048517)
- *9161B Installation Manual* (Intermec Part No. 049572)
- *9180 Network Controller User's Manual* (Intermec Part No. 054292)
- *RF System User's Manual* (Intermec Part No. 053574)
- *Data Communications Reference Manual* (Intermec Part No. 044737)

If you need to change the printer's communications parameters, follow the procedures in "Configuring the Serial Port" in Chapter 1.





## ***Glossary***



***ASCII***

American Standard Code for Information Interchange. A standard seven bit code almost always transmitted with a parity bit for a total of eight bits per character. The American National Standards Institute established ASCII to achieve compatibility between various types of data communication equipment. It is equivalent to the International ISO 7-bit code.

***backing***

Silicon release liner on media to which labels stay attached until they are ready for use.

***bar code***

A printed, machine-readable code that consists of parallel bars of varied width and spacing.

***batch takeup***

A device that rewinds media; useful for printing batches of labels.

***BEL***

A command character that instructs the printer to return an error status code.

***character set***

Refers to the letters, numerals, and symbols that support a particular language (such as French, U.S., ASCII) or automatic identification technology (such as Code 30, Codabar).

***configuration***

The current parameter settings that determine the operating characteristics of the printer.

***data file***

The collection of data and printer commands that, when sent to the printer, merges with a format file to print a label.

***Data Line Print mode***

A mode of operation in which the printer prints each command (accompanied by its ASCII code) that it receives from the host.

***density***

Number of data characters that you can represent in a linear unit of measure. Often expressed in characters per inch.

***direct thermal***

A method of thermal printing in which images print when heat from the thermal printhead produces a black mark on the media.

***drag***

A method of bar code printing in which all the bars print at once, in parallel. The bar code appears across the width of the label.

***DRAM***

Dynamic random access memory. DRAM is a high speed read/write memory that retains data for a short period of time.

***EAN***

European Article Numbering; now also called IAN (International Article Numbering). International standard bar code for retail food packages corresponding to the Universal Product Code (UPC) in the United States.

***edge guide***

An adjustable guide you use to keep the media in the correct position as it moves through the media path. You can adjust it to accommodate varying media widths.

***Emulation mode***

An operating mode in which the printer has the operating characteristics of another printer. The 3240 can operate in 8636/46 Emulation, which emulates an Intermec 8636 or 8646 printer.

***Feed/Pause***

A printer control panel button that advances the media and causes the printer to pause printing.

***field***

A graphic element that is the basic unit of a format. The four basic types of fields are bar code, graphic, line, and text.

***fixed data field***

Bar code and text fields that never vary from one label to the next; the data in a fixed field is a permanent part of the format.

***fixed format***

A format in which the data never varies from one label to the next, such as a return address label. A fixed format needs no additional data to print a label.

***font***

A character set of a given type size and style. See also character set.

***font file***

See soft font.

***format file***

A collection of printer commands and data that determines the arrangement of fields on a label.

***graphic***

A bitmap picture downloaded to the printer by the host before printing.

***head lift lever***

The lever you use to raise the printhead.

***HIBC***

Health Industry Bar Code standard. A modified version of Code 39 that has 43 characters, utilizes the Modulus 43 check character, and reserves some character combinations for special usage.

***high registration***

The ability of the printer to control the exact placement and quality of label images it prints.

***human-readable***

A character, number, or symbol printed in a font that a human can read; as opposed to bar code symbology, which only a machine can read. See text.

***image bands***

A portion of an image in the shape of a strip of the image. The printer stores a certain number of image bands in memory before printing begins. This method allows printing and imaging to take place simultaneously.

***imaging***

The process of generating a picture of the label in printer memory.

***increment/decrement field***

Bar code or text fields the printer automatically changes from one label to the next. For example, a batch of labels with serial number text or bar code fields, that change from 001, to 002, to 003, and so on.

***index***

To move from the start of the label to the start of print. With continuous media, to advance the media over the "label gap" to the "edge" of the next label.

***interpretive field***

A text field that describes the data in the associated bar code field.

***ips***

Inches per second. A measurement of print speed that measures the number of inches of media that prints each second.

***ISO***

International Organization for Standardization. An internationally accepted 7-bit character code. (The U.S. version is ASCII.)

***label***

The part of the media on which data prints.

***label format***

The design of a bar code label; the arrangement of the text, lines, and bar codes on a label.

***label gap***

The space between labels on die-cut label stock.

***margin***

The distance between the edge of a label and where the printing starts on that label. *See also* top of form.

***media***

The label stock on which the printer prints labels. Types of media include plain paper, polyester, thermally reactive paper, or other materials with adhesive backing.

***media sensitivity number***

A three-digit number that specifies the amount of heat the printhead requires to image a label. Media sensitivity numbers are specific to a particular type of media.

***mnemonic code***

An acronym or abbreviation for a computer instruction, routine, or format. For example, <STX> represents the start of text.

***Multi-Drop protocol***

A protocol capable of controlling communications between a single controller and multiple devices.

***nibblized***

A software term that refers to grouping bits into sets of four, called nibbles. Usually bits are grouped into sets of eight, which are called bytes.

***OCR font***

A font that is recognized by optical character recognition.

***offline***

The state in which the printer is not able to carry out two-way communication with the host.

***online***

The state in which the printer is able to carry out two-way communication with the host.

***page***

A group of labels that always print together. When labels on a page share the same data, it reduces the number of commands that you must send to the printer.

***parallel***

A communication scheme in which the bits of a byte are transferred simultaneously over a multistrand cable.

***parameters***

The operating limits of the printer. Also, the variable information sent with a command.

***picket***

A method of bar code printing in which the bars in the bar code print one at a time, in a series. The bar code appears along the length of the label.

***pitch***

(1) The number of characters printed in one horizontal inch determined by the increment by which the printer platen moves. (2) Rotation of a bar code symbol about an axis parallel to the direction of the bars.

***point size***

A unit of measure for font height; 72 points equals 1 inch as measured from slightly above the top of the uppercase letters to slightly below the bottom of the lowercase descenders.

***Polling Mode D***

Polling Mode D is a protocol that allows devices and controllers to exchange data in an “ask and receive” format. Use Polling Mode D to connect multiple devices to a single multiport controller.

***Precision Print™***

Precision Print is the term Intermec uses to describe the software and adjustable hardware features of the 3240 printer that enable it to print high registration labels.

***print speed***

Measured in inches per second (ips), the rate at which media travels past the printhead.

***printhead***

The mechanism inside the printer that prints. The printhead for the 3240 printer consists of 1024 thermal elements.

***printhead elements***

The parts of the printhead that print by placing a mark on the label when heated. Each element is 0.0025 square inches in area and switches on and off separately in order to react with the media or thermal transfer ribbon to create a mark on the label.

***ready***

The state in which the printer is able to print; the normal operating state of the printer.

***Ready/Busy line***

Pin 11/20 of the rear panel connector. Indicates the printer is ready or not ready.

***RS-232***

Widely recognized protocol standard for serial binary data interchange. The standard covers the physical, electrical, and functional characteristics of the interface.

***RS-422***

Standard for the voltage and impedance levels for serial data transmission on balanced lines. Similar to RS-232, but handles larger distances and faster communication.

***RS-485***

Standard for allowing multiple devices to share a common set of serial data communication lines. The signaling is very similar to RS-422. The maximum number of devices allowed is 32.

***scan***

To read a bar code with a device known as a scanner that converts optical information into electrical signals.

***scannable***

A symbol that you can successfully scan and correctly decode.

***selective transfer***

A procedure that copies selected formats, fonts, graphics, or pages stored in the memory of one printer to the memory of another.

***self-strip***

An optional device for the 3240 printer that presents each label after it prints, with the backing removed so you can apply it immediately.

***sensitivity***

The responsiveness of thermal media, or of thermal transfer ribbon, to heat; it is determined by the time required for a unit measure of heat to affect the media or ribbon.

***serial***

A communication scheme in which the bits of a byte are transferred one at a time. Often serial transmission is used to link host computers to terminals and PCs to printers.

***skip***

To move the paper to the next label.

***soft font***

A file stored in the printer to provide the ability to print text using fonts that are not resident in the printer.

***SRAM***

Static random access memory. SRAM is a high-speed read/write memory that retains data indefinitely while you apply power to the chip.

***Standard protocol***

A communications protocol capable of controlling communications between two devices connected by a single data communication line.

***symbology***

A scheme for encoding data as bar code. Code 39, Interleaved 2 of 5, and Codabar are examples of different symbologies.

***thermal transfer***

A method of printing by which heat from the printhead melts ink from the ribbon onto media. The ink adheres to the media as it cools.

***top of form***

The point where printing can start on a label. Separated from the edge of the label by the margin.

***User-Defined Characters (UDC)***

See graphic.

***User-Defined Fonts (UDF)***

See soft font.

***variable data field***

Bar code and text fields that change from one label to the next.

***XON/XOFF***

A protocol that stops the host from sending data when the printer buffer fills up and starts it again when the buffer empties.

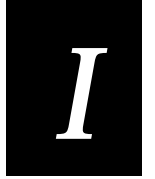

***Index***



**Numbers**

- 3400 printer, differences from the 3240, 5-24
- 4100 printer, differences from the 3240, 5-23
- 86XX printer, differences from the 3240, 5-19
- 86XX Emulation mode, 5-17
  - international character sets, A-17
  - setting with DIP switches, 5-17

**A**

- AC power receptacle, 1-7
- adjustments
  - bias adjust screw, 4-17
  - darkness adjust, 4-11
  - label gap sensor, 4-15
  - lateral printhead knob, 4-13
- Advanced mode, international character sets, A-16
- Alert LED, 2-4
- AS/400, connecting to the 3240, 1-16
- ASCII chart, A-25

**B**

- bar code
  - orientation
    - selecting correct, 4-10
    - selecting for optimal print quality, 4-10
  - symbolologies, A-13
    - Codabar, A-13
    - Code 11, A-13
    - Code 128, A-14
    - Code 16K, A-13
    - Code 2 of 5, A-13
    - Code 39, A-13
    - Code 49, A-13
    - Code 93, A-14
    - Code One, A-14
    - Data Matrix, A-14
    - EAN, A-14
    - HIBC, A-14
    - Interleaved 2 of 5, A-14
    - MaxiCode, A-15
    - PDF417, A-15
    - POSTNET, A-15
    - UPC, A-15
- batch printing, optimizing with image bands, 5-7
- batch takeover option, A-11
- bias adjust screw
  - adjusting, 4-17
  - using for optimal print quality, 4-17

**C**

- cables, B-8, B-11
  - considerations, B-14
  - Intermec, B-11

- Multi-drop, B-14
  - RS-232 schematics, B-12
  - RS-422 schematic, B-13
  - RS-485 (Multi-Drop), B-14
    - schematics, B-11
    - straight through schematics, B-13
- Centronics parallel interface, A-12
- changing serial port settings, 1-17
- character sets
  - extended, A-19–A-23
  - international, A-16
- cleaning
  - drive roller, 3-8
  - label sensors, 3-12
  - media guides, 3-10
  - media path, 3-10
  - printer, 3-3
  - printer covers, 3-7
  - printhead, 3-6
  - tear bar, 3-8
- coax interface option, A-11
- Codabar, description of, A-13
- Code 11, description of, A-13
- Code 128, description of, A-14
- Code 16K, description of, A-13
- Code 2 of 5, description of, A-13
- Code 39, description of, A-13
- Code 49, description of, A-13
- Code 93, description of, A-14
- Code One, description of, A-14
- communicating with the host test, 1-19
- communicating with the printer, 2-17
  - not from a PC, 2-19
  - using IPL commands, 2-17
  - using the PrintSet software, 2-17
  - using third-party software, 2-17
- communications
  - boundaries, A-10, B-3
  - checking for problems, 4-8
  - data loss, preventing, 4-8
  - host requirements, B-3
  - interfaces, B-8
  - problems, 4-7
  - protocols, B-4
  - reference, B-3
  - table, A-9
  - testing for, 1-19
  - troubleshooting printer, 5-10
    - See also protocols
- configuration, printing test label, 5-10
- configuration commands
  - changing from Test and Service mode, 5-13
  - 86XX Emulation mode, 5-13
  - label rest point, 5-13, 5-15
  - setting the number of dot increments, 5-14

## 3240 Bar Code Label Printer User's Manual

### configuration commands (*continued*)

- changing from Test and Service mode, 5-13
  - X forms adjust, 5-13
  - Y forms adjust, 5-13
- DIP switch settings, 5-13
- configuration parameters upload table, A-8
- configuration test labels
  - hardware, 1-12
  - software, 2-13
- configuring the serial port, 1-17
- connecting
  - printer to a mainframe, 1-16
  - printer to a network, 1-15
  - printer to an AS/400, 1-16
  - printer to a PC, 1-14
  - printer to system, 1-13
  - using the parallel port, 1-15
  - using the serial port, 1-14

### connectors, B-11

## D

- darkness adjust control
  - setting, 4-11
  - using for optimal print quality, 4-11
- Data Line Print, 5-10
  - entering, 5-10
  - using to test for communication with the host, 1-19
  - using to test the operation of the printer, 5-10
  - using to troubleshoot printer, 5-10
- data loss
  - checking for communication problems, 4-8
  - preventing, 4-8
- Data Matrix, A-14
- default settings, *See* factory default settings
- DIP switch settings, A-24
  - changing, 1-18
  - configuration commands, 5-13
  - table, 1-18
  - test and service, 5-9
  - switches for setting dot increments, 5-14
  - Test and Service, 5-9
- dot increments, setting the number of, 5-14
- drive roller, cleaning, 3-8

## E

- EAN, description of, A-14
- Empty/Pause LED, 2-4

## F

- factory default settings, A-6
- fanfold media, loading, 2-6
- Feed/Pause button, using, 2-5
- Feed/Pause LED, 2-4
- fields, reimage modified, *See* reimage modified fields

### fonts

- and graphics, A-5
  - copying to another printer, 5-11
  - extended character sets, A-19 to A-23
  - standard, A-19
  - tables, A-19
- ### format
- boundaries, A-9
  - copying to another printer, 5-11
- ### front panel
- illustration of, 2-3
  - LEDs, 2-4
  - understanding the, 2-3
- ### full ASCII chart, A-25
- ### functional boundaries, printer, A-9

## G, H

- graphics, copying to another printer, 5-11
- hardware configuration test label, 1-12
- HIBC, description of, A-14
- high registration labels, printing, 4-13

## I

- IBM language translation character table, A-17
- image bands
  - description, 5-5
  - optimizing, 5-6
  - optimizing with print speed, 5-6
  - using for batch printing, 5-7
- installation
  - modem, B-15
  - network, B-15
  - printer, 1-7
- interfaces
  - cables and connectors, B-11
  - RS-232, B-8
  - RS-422, B-8
  - RS-485, B-8
  - table of pin-outs, B-9
- Interleaved 2 of 5, description of, A-14
- Intermec Standard protocol, B-4
- international character Sets, A-16

## J, K, L

- Kanji/Katakana option, A-11
- label
  - detecting the start, 4-15
  - formats
    - positioning along the length of label, 5-21
    - positioning parallel along width of label, 5-22
  - gap sensor, adjusting, 4-15
  - high registration, 4-13
  - image, adjusting the lateral position, 4-13
  - rest point, setting with DIP switches, 5-15

label (*continued*)  
 sensors, cleaning, 3-12  
 taken sensor, adjusting for use with self-strip, 4-12  
*See also* fields, formats

languages, international character sets, A-16

lateral position, correcting for label image, 4-13

lateral printhead knob, using to correct label image position, 4-13

#### LEDs

front panel, 2-4  
 indicators, 2-4  
 media or system faults, 2-4  
 over-temperature condition, 2-4  
 understanding, 2-4

#### loading

fanfold media, 2-6  
 media for self-strip printing, 2-8  
 media for straight-through printing, 1-9, 2-7  
 roll media, 1-9  
 thermal transfer ribbon, 1-9, 2-11

## M

mainframe, connecting to the 3240, 1-16

maintenance, 3-3  
 location of parts to be maintained, 3-5  
 schedule, 3-4

MaxiCode, description of, A-15

media  
 guides, cleaning, 3-10  
 selecting correct, 4-9  
 system faults, 2-4

media sensitivity  
 number, description of, 2-13  
 selecting the correct number, 4-10  
 setting for Intermec media and ribbon, 2-14  
 setting for other media and ribbon, 2-15  
 settings table  
 direct thermal media, 2-15  
 thermal transfer ribbon and media, 2-16

memory  
 increasing amount available, 5-4, 5-12  
 returning printer to default settings, 5-12  
 reset, 5-12  
 expansion option, A-11  
 usage  
 limitations, 5-4  
 problem, 5-4

modem installation, B-15

Multi-Drop cables, B-14

Multi-Drop protocol, B-6

## N, O

network  
 connecting to the 3240, 1-15

installation, B-15

ON/OFF switch, 1-7

opening the printer, 1-8

operating the printer, 2-3

options, printer, A-11

over-temperature condition, 2-4

## P, Q

pages, copying to another printer, 5-11

parallel port, using to connect the 3240 to a PC, 1-15

PDF417, description of, A-15

plugging in the printer, 1-7

polling mode D protocol, B-6

POSTNET, description of, A-15

Power LED, 2-4

Precision Print  
 adjustments, 4-13  
 definition, 4-13

print darkness, adjusting with darkness adjust control, 4-11

print quality  
 correcting uneven, 4-17  
 maintaining, 4-9  
 optimizing, 4-9, 4-10  
 printing test label, 5-10  
 problems, 4-5  
 understanding, 4-9

print speed  
 adjusting for use with image bands, 5-6  
 setting for optimal print quality, 4-10  
 using in conjunction with image bands, 4-10

printer  
 cleaning, 3-3  
 communication, 2-17  
 communication boundaries, A-10  
 components  
 back view, 1-6  
 front view, 1-5  
 connecting  
 to a PC, 1-14  
 to a mainframe, 1-16  
 to a network, 1-15  
 to an AS/400, 1-16  
 to your system, 1-13  
 cover  
 cleaning, 3-7  
 removing, 1-8  
 format boundaries, A-9  
 functional boundaries, A-9  
 installation, 1-7  
 maintenance, 3-3  
 memory  
 expansion, A-11  
 using, 5-3  
 opening, 1-8

printer (*continued*)  
operation, 2-3  
problems, 4-3  
testing, 5-10  
troubleshooting, 5-10  
options, A-11  
memory expansion, A-11  
batch takeup, A-11  
centronics parallel interface, A-12  
coax interface, A-11  
Kanji/Katakana, A-11  
twinax interface, A-11  
printer RAM  
allocation, 5-3  
storage limitations, 5-3  
using, 5-3  
printhead, cleaning, 3-6  
printing  
correcting problems with self-strip, 4-12  
fanfold, 2-6  
hardware configuration label, 1-12  
high registration labels, 4-13  
increasing speed, 5-5  
self-strip, 2-8  
software configuration label, 2-13  
straight through, 1-9, 2-7  
problems  
communication, 4-7  
print quality, 4-5  
printer operation, 4-3  
protocols, B-4  
multi-drop, B-6  
polling mode D, B-6  
Standard, B-4  
user-defined, B-6  
XON/XOFF, B-5

## **R**

RAM, printer, 5-3  
reimage modified fields, 5-7  
removing the printer cover, 1-8  
replacing  
a 3400 printer with a 3600 printer, 5-19  
a 4100 printer with a 3600 printer, 5-19  
an 86XX printer with a 3600 printer, 5-19  
RS-232 serial interface, B-8  
RS-422 serial interface, B-8  
RS-485 serial interface, B-8

## **S**

schedule of maintenance, 3-4  
selective transfer, 5-11  
self-strip printing, 2-8  
adjusting the label taken sensor, 4-12

adjusting the printer, 4-12  
sensitivity number, setting for optimal print quality,  
4-10  
serial port  
configuration, 1-17  
description, B-10  
settings, changing, 1-18  
using to connect a PC to the 3240, 1-14  
setting  
media sensitivity number, 2-13  
serial port, 1-17  
skipping labels, adjusting the printer to stop, 4-15  
*See also* self-strip printing  
software configuration label, printing, 2-13  
specifications, printer, A-3 to A-5  
straight-through printing, 1-9  
symbolologies  
bar code, A-13  
Codabar, A-13  
Code 11, A-13  
Code 128, A-14  
Code 16K, A-13  
Code 2 of 5, A-13  
Code 39, A-13  
Code 49, A-13  
Code 93, A-14  
Code One, A-14  
Data Matrix, A-14,  
EAN, A-14  
HIBC, A-14  
Interleaved 2 of 5, A-14  
MaxiCode, A-15  
PDF417, A-15  
POSTNET, A-15  
UPC, A-15

## **T**

tear bar, cleaning, 3-8  
Test and Service Mode, 5-8  
adjusting label rest point, 5-15  
changing configuration commands from, 5-13  
Data Line Print, 5-10  
DIP switch settings, 5-9  
entering, 5-8  
memory reset, 5-12  
printing test labels, 5-10  
selective transfer, 5-11  
setting 86XX Emulation mode, 5-17  
setting number of dot increments, 5-14  
test labels, printing, 5-10  
testing for communication with host, 1-19  
thermal transfer ribbon, loading, 1-9, 2-11  
third-party software, using to communicate with the  
printer, 2-17  
throughput, maximum processing, 5-5

troubleshooting, 4-3  
  checklist, 4-3  
  communication problems, 4-7  
  print quality problems, 4-5  
  printer operation problems, 4-3  
twinax interface option, A-11

***U, V, W***

UPC, description of, A-15  
user-defined protocol, B-6

***X, Y, Z***

x forms adjust, moving forward or backward with DIP  
  switches, 5-14  
XON/XOFF protocol, B-5

